

# Installation Guide

## Multi Position Servo Controller

### *E1100-MP and E1100-MP-HC*

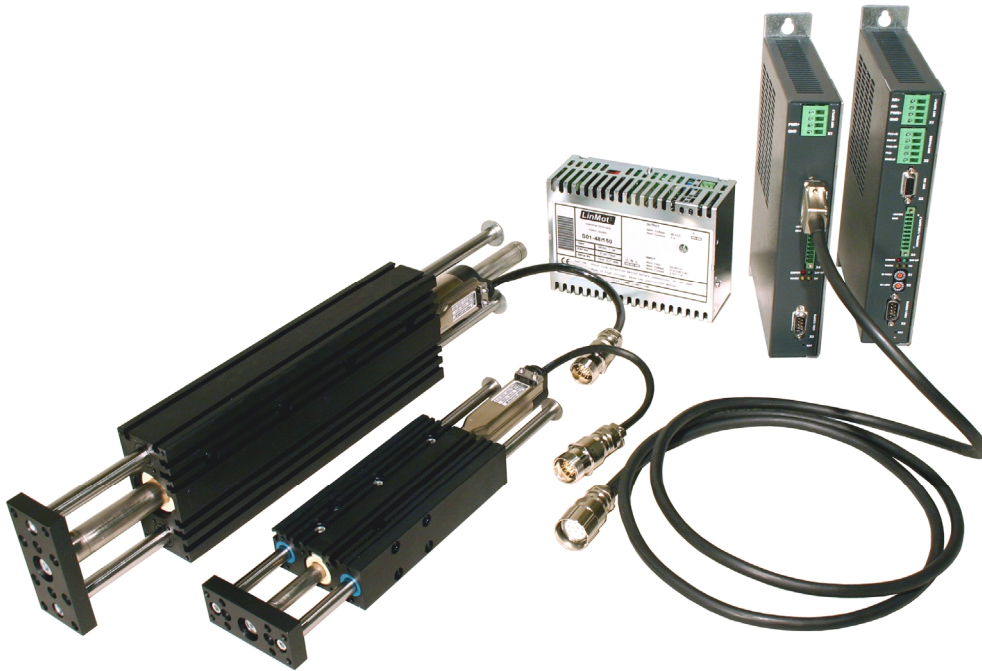

## Content

IMPORTANT NOTES FOR E1100 SERIES CONTROLLERS	2
SYSTEM OVERVIEW	3
E1100-MP SERIES FUNCTION AND WIRING	4
E1100-MP-HC SERIES FUNCTION AND WIRING	5
POWER SUPPLY AND GROUNDING	5
DESCRIPTION OF THE CONNECTORS / INTERFACES	6
PHYSICAL DIMENSION	11
POWER SUPPLY REQUIREMENT	12
REGENERATION OF POWER / BLEEDING RESISTOR	12
ORDERING INFORMATION	12
DECLARATION OF CONFORMITY CE-MARKING	13
ERROR CODES	14
CONTACT ADDRESSES	15

**Important notes for E1100 series controllers**

**CAUTION !!**



In order to assure a safe and error free operation, and to avoid severe damage to system components, all system components must be directly attached to a single ground bus that is earth or utility grounded (see chapter Power Supply and Grounding).



Each system component should be tied directly to the ground bus (star pattern), rather than daisy chaining from component to component. (LinMot motors are properly grounded through their power cables when connected to LinMot controllers) (see chapter Power Supply and Grounding).



All connectors must not be connected or disconnected while DC voltage is present. Do not disconnect system components until all LinMot controller LED's have turned off. (Capacitors in the power supply may not fully discharge for several minutes after input voltage been disconnected). Failure to observe these precautions may result in severe damage to electronic components in LinMot motors and/or controllers.



Do not switch Power Supply DC Voltage. All power supply switching and E-Stop breaks should be done to the AC supply voltage of the power supply.



Do not connect or disconnect the motors from controllers with voltage present. Wait to connect or disconnect motors until all LinMot controller LED's have turned off. (Capacitors may not fully discharge for several minutes after power has been turned off). Failure to observe these precautions may result in severe damage to electronic components in LinMot motors and/or controllers.

© 2004 NTI Ltd

This work is protected by copyright.

Under the copyright laws, this publication may not be reproduced or transmitted in any form, electronic or mechanical, including photocopying, recording, microfilm, storing in an information retrieval system, not even for didactical use, or translating, in whole or in part, without the prior written consent of NTI AG.

LinMot® is a registered trademark of NTI AG.

Note

The information in this documentation reflects the stage of development at the time of press and is therefore without obligation. NTI AG. reserves itself the right to make changes at any time and without notice to reflect further technical advance or product improvement.

**System Overview**

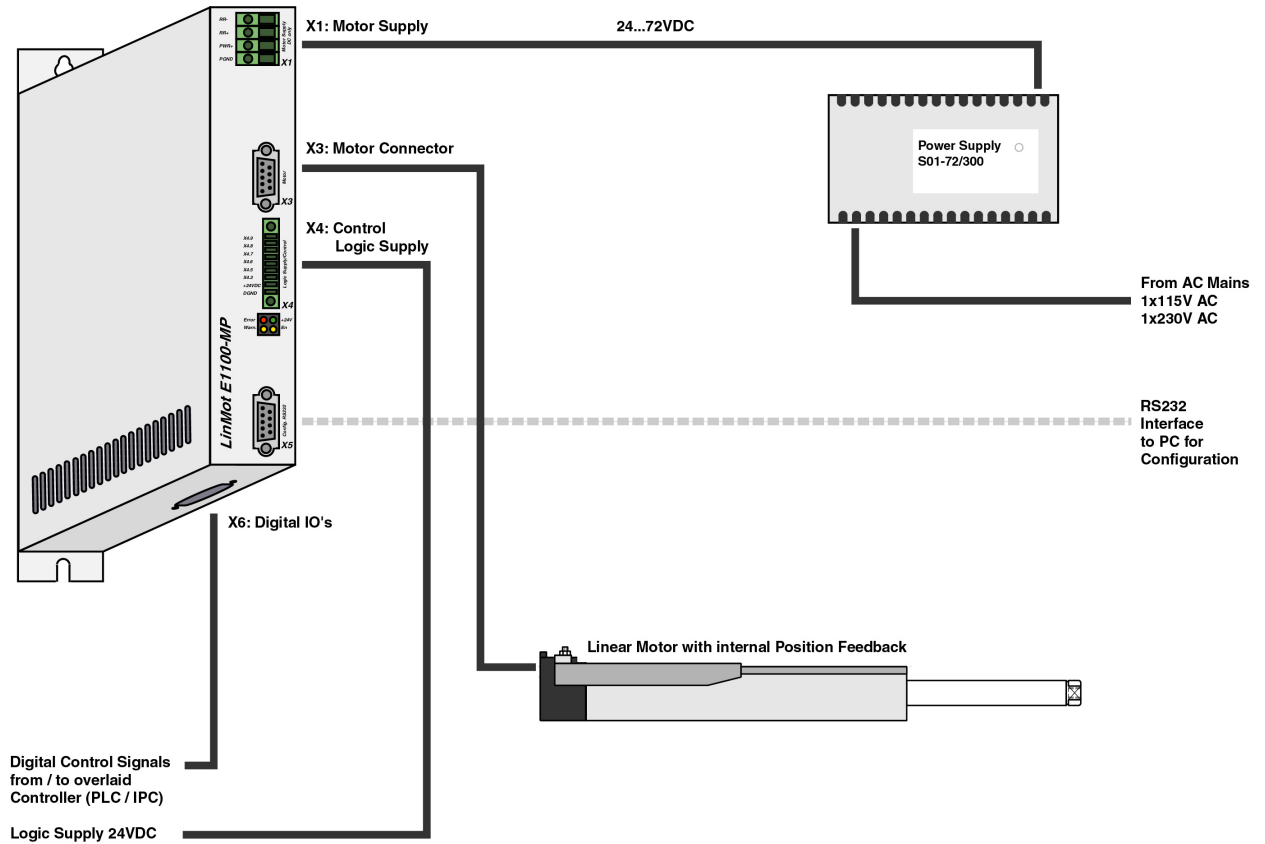

Complete Multi Position Servo System E1100-MP Servo Controller, Linear Motor and Power Supply.

## E1100-MP Series Function and Wiring

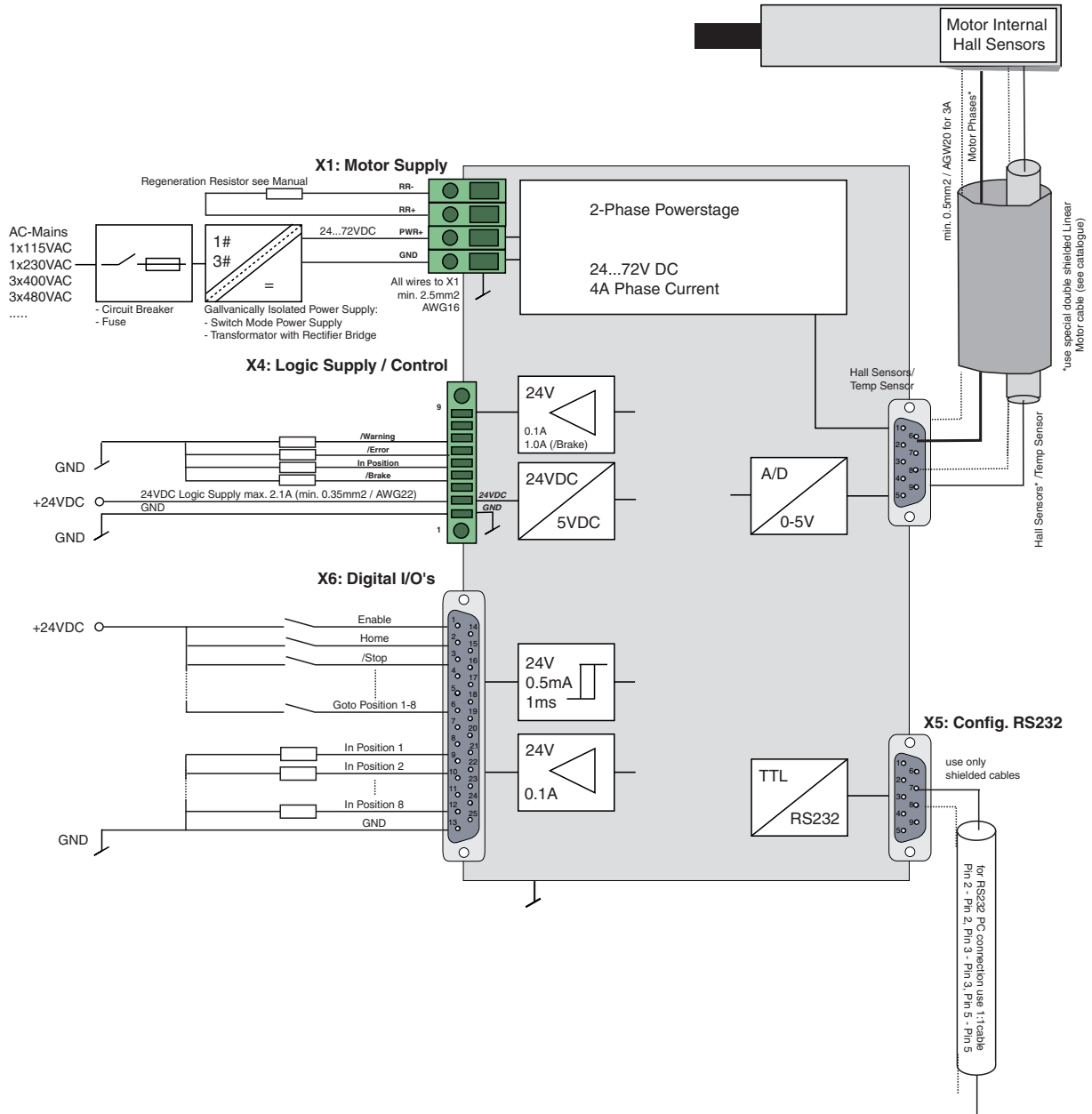

Multi Position Servo System E1100-MP Servo Controller, Linear Motor and Power Supply. All connections for the motor are done within the DSUB-9 connector.



## Power Supply and Grounding

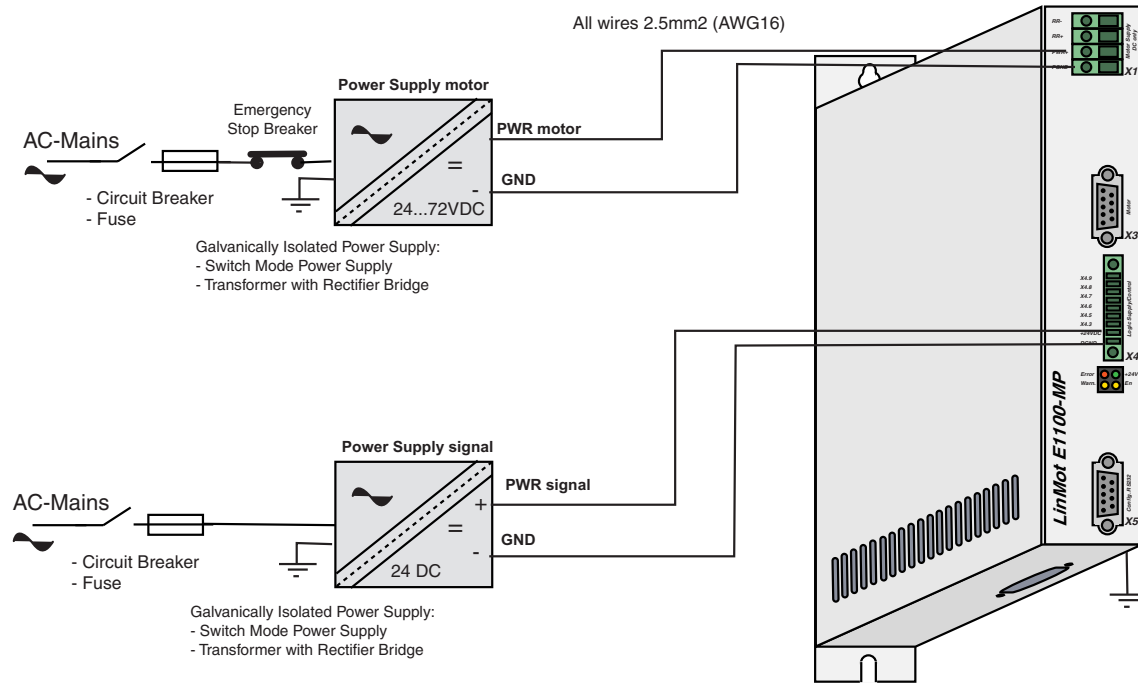

\*Inside of the E1100 controller the *PWR motor GND* and *PWR signal GND* is connected together and to the GND of the controller housing. It is recommended that the *PWR motor GND* is NOT grounded at another place than inside of the controller to reduce circular currents.



In order to assure a safe and error free operation, and to avoid severe damage to system components, **all system components\* must be well grounded to either a single earth or utility ground.** This includes both LinMot and all other control system components to the same ground bus.



Each system component\* should be tied directly to the ground bus (**star pattern**), rather than daisy chaining from component to component. (LinMot motors are properly grounded through their power cables when connected to LinMot controllers.)



**Power supply connectors must not be connected or disconnected while DC voltage is present.** Do not disconnect system components until all LinMot controller LED's have turned off. (Capacitors in the power supply may not fully discharge for several minutes after input voltage been disconnected). Failure to observe these precautions may result in severe damage to electronic components in LinMot motors and/or controllers.



**Do not switch Power Supply DC Voltage.** All power supply switching and E-Stop breaks should be done to the AC supply voltage of the power supply. Failure to observe these precautions may result in severe damage to controller.

## Description of the connectors / Interfaces

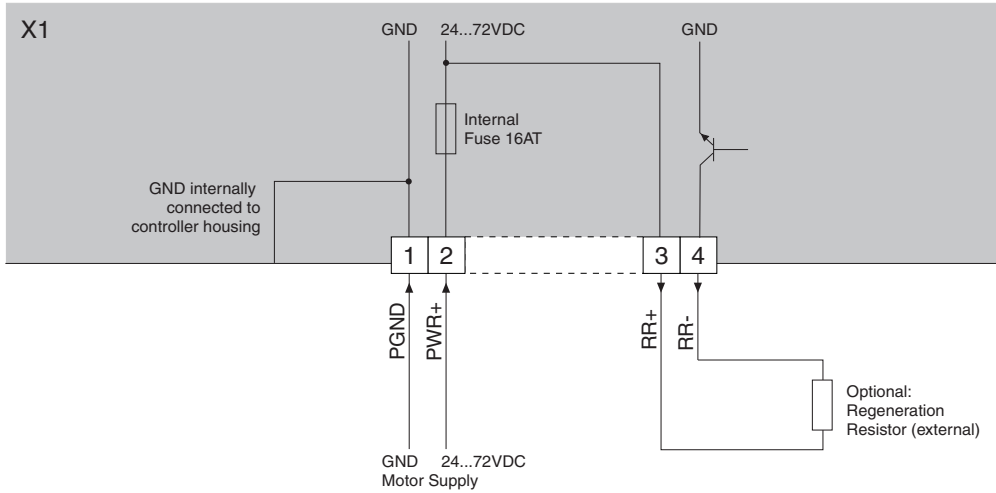

X1	Motor Supply
 <p>Screw Terminals</p>	
	<p><b>Motor Supply:</b> Motor Supply Voltage 24...72VDC. Absolute max. Rating 72VDC +10%.</p> <p>Note: Inside of the E1100 controller the <i>PWR motor GND</i> and <i>PWR signal GND</i> is connected together and to the GND of the controller housing</p> <p><b>Regeneration Resistor:</b> Optional external Regeneration Register for long stroke movements with high velocity and fast stops. Only needed if Motor Supply voltage during stops exceeds the max. limit. Use only Regeneration Resistor RR01-10/60 (10 Ohm, 60 W Part-No 0150-3088) or RR01-10/150 (10 Ohm, 150 W Part-No 0150-3088)</p> <p><b>Caution:</b> Exceeding 90VDC supply voltage, the controller will go into error state and may be damaged.</p> <p><b>Wiring:</b> 2.5mm<sup>2</sup> (AWG 14)</p>

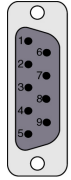
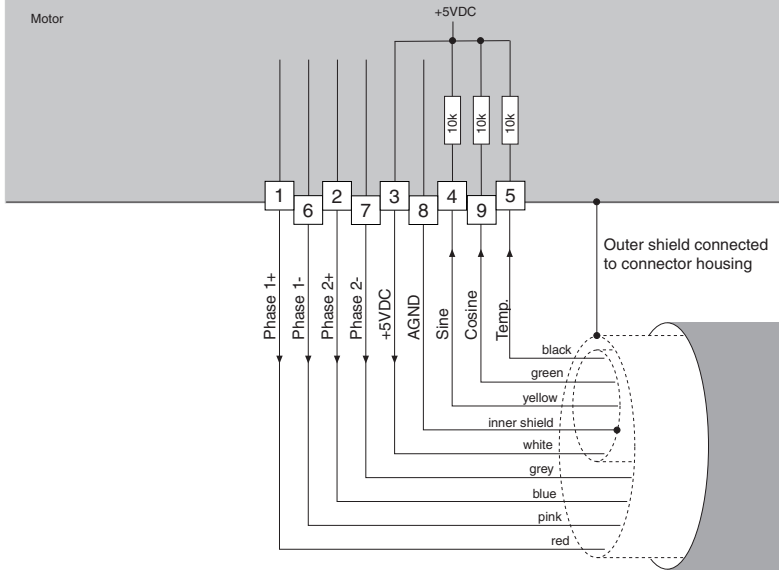
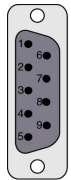
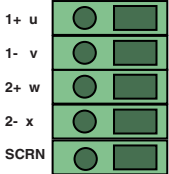
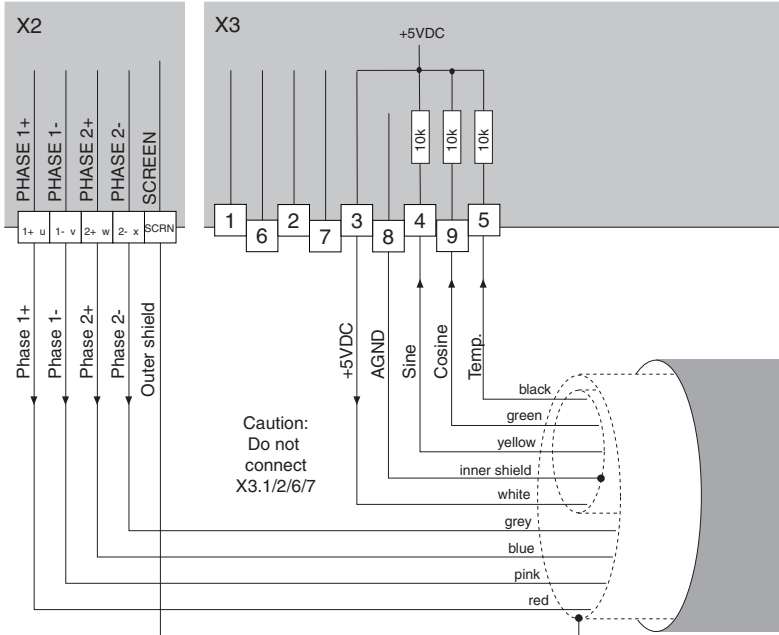
# Multi Position Controller *E1100-MP / -MP-HC* **LinMot®**

X3	Motor Connector for <i>E1100-MP</i> and <i>E1100-MP-HC</i> with less than 5A rms
 <p>DSUB-9 (f)</p>	 <p>Note: <i>E1100-MP-HC</i>: If motor current exceeds 5 Arms, then use x2 connector for phases!</p>
X2 & X3	Motor Connector for <i>E1100-MP-HC</i> Version
 <p>DSUB-9 (f)</p>  <p>X2</p> <p>1+ u 1- v 2+ w 2- x SCRN</p>	 <p>Caution: Do not connect X3.1/2/6/7</p>
	<p><u>Note:</u></p> <ul style="list-style-type: none"> <li>- PS01-48x.. and PS01-37x240-F stators must be connected to X2 and X3 connectors of <i>E1100-MP-HC</i> controllers</li> <li>- Use only special double-shielded Linear Motor Cable.</li> <li>- Use +5V (X3.3) and AGND (X3.8) only for motor internal Hall Sensor supply (max. 100mA).</li> <li>- Do NOT connect AGND (X3.8) to ground or earth!</li> <li>- Inner shield (AGND) and outer shield (earth) must be isolated to each other.</li> </ul> <p><u>Caution:</u></p> <ul style="list-style-type: none"> <li>- Wrong Motor wiring may damage Linear Motors and/or Servo Controller.</li> <li>- If you are assembling motor cable by your own, double check motor wiring carefully before power up.</li> </ul>

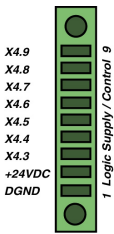
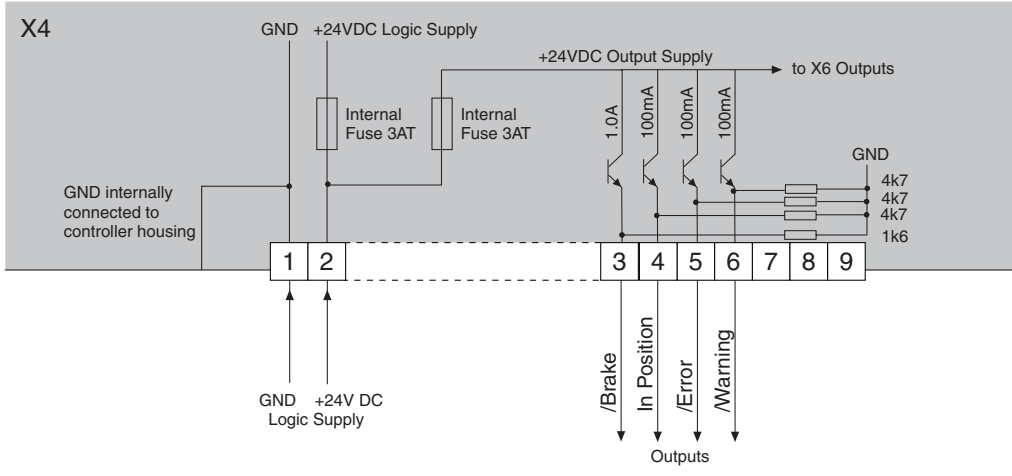

# Multi Position Controller *E1100-MP / -MP-HC* **LinMot®**

X4	Control / Logic Supply	
 <p>X4.9 X4.8 X4.7 X4.6 X4.5 X4.4 X4.3 +24VDC DGND</p>	 <p>X4</p> <p>GND +24VDC Logic Supply</p> <p>Internal Fuse 3AT</p> <p>Internal Fuse 3AT</p> <p>+24VDC Output Supply → to X6 Outputs</p> <p>1.0A</p> <p>100mA</p> <p>100mA</p> <p>100mA</p> <p>GND</p> <p>4k7</p> <p>4k7</p> <p>4k7</p> <p>1k6</p> <p>1 2 3 4 5 6 7 8 9</p> <p>GND +24V DC Logic Supply</p> <p>/Brake</p> <p>In Position</p> <p>/Error</p> <p>/Warning</p> <p>Outputs</p>	
	<p><b>Digital I/O's:</b></p> <p>Inputs 24V / 5mA / 1msec (Trigger Input 0.25msec)</p> <p>Outputs 24V / max.100mA (Break Output max.1A)</p> <p><b>Supply:</b></p> <p>24VDC min. 100mA (no load on the outputs)</p> <p>typ. 1.1A (all 10 outputs "on" with 100mA load and /Break with no load)</p> <p>max. 2.1A (all 10 outputs "on" with 100mA load and /Break with 1A load)</p> <p>Wiring: 0.2-1.5mm<sup>2</sup> (AWG24-16)</p>	
LED	State Display	
 <p>Error 24V OK</p> <p>Warn EN</p>	<p>Green 24V Logic Supply OK</p> <p>Yellow Motor Enabled</p> <p>Yellow Warning</p> <p>Red Error</p>	

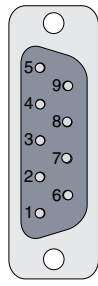
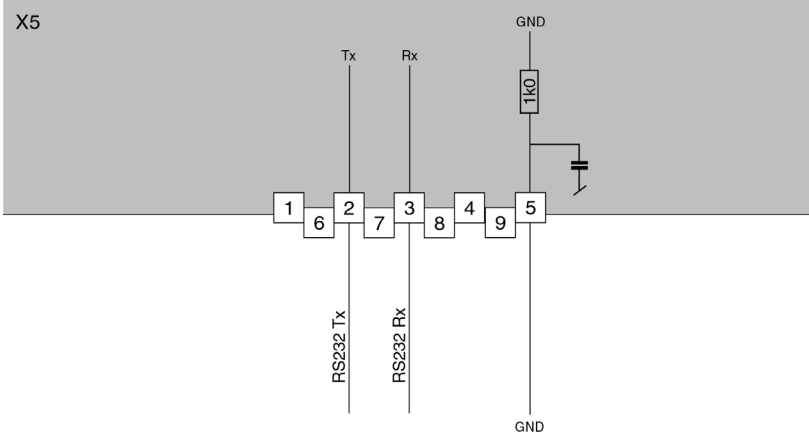
X5:	COM	
 <p>DSUB-9 (m)</p>	 <p>X5</p> <p>Tx</p> <p>Rx</p> <p>GND</p> <p>T1K0</p> <p>1 6 2 7 3 8 4 9 5</p> <p>RS232 Tx</p> <p>RS232 Rx</p> <p>GND</p>	
	<p><b>RS232:</b> 38.4kBaud, use 1:1 connection cable to PC</p>	

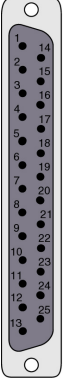
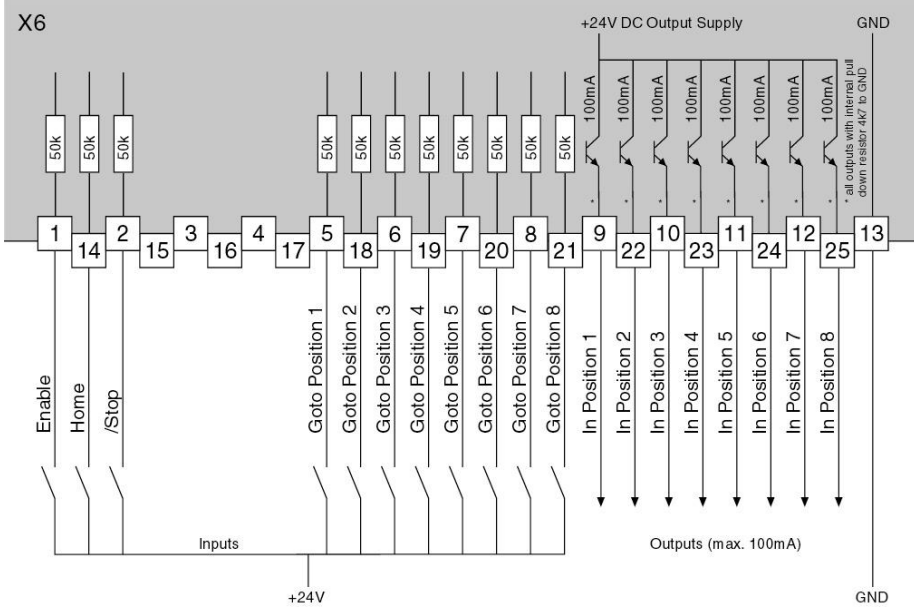
X6:	Digital I/O
 <p>DSUB-25 (f)</p>	 <p>X6</p> <p>+24V DC Output Supply</p> <p>GND</p> <p>50k 50k 50k</p> <p>1 14 2 15 3 16 4 17 5 18 6 19 7 20 8 21 9 22 10 23 11 24 12 25 13</p> <p>Enable Home /Stop</p> <p>Goto Position 1 Goto Position 2 Goto Position 3 Goto Position 4 Goto Position 5 Goto Position 6 Goto Position 7 Goto Position 8</p> <p>In Position 1 In Position 2 In Position 3 In Position 4 In Position 5 In Position 6 In Position 7 In Position 8</p> <p>Inputs</p> <p>Outputs (max. 100mA)</p> <p>+24V</p> <p>GND</p> <p>* all outputs with internal pull down resistor 4kΩ to GND</p>
	<p><b>All Inputs:</b>            Direct interfacing to digital 24VDC PLC outputs.            Max. Low Level: &lt;1.5V      Min. High Level: &gt;4.0V            Input current: 0.5mA      Sample rate: 1ms</p> <p><b>All Outputs:</b>            Short circuit and overload protected high side switches            Voltage: 24VDC      Max. Output current: 100mA            Update rate: 1ms</p> <p>Outputs may directly drive inductive loads.</p>

## Physical Dimension

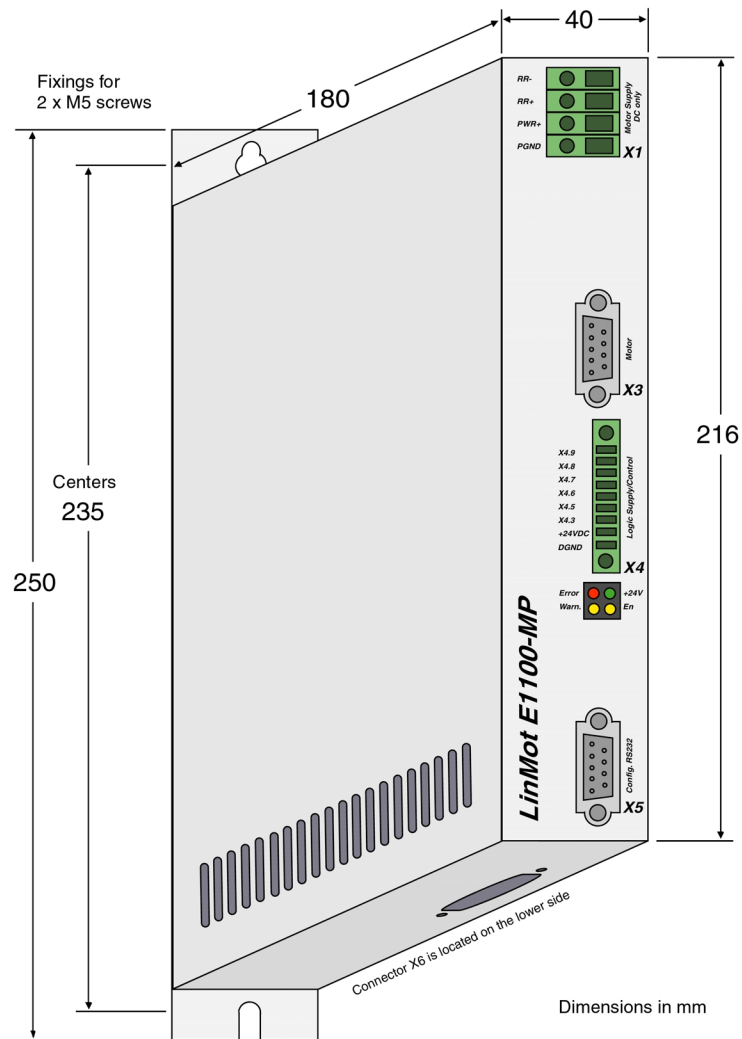

<b>E1100-MP / E1100-MP-HC</b> Single axes controller		
Width	mm (in)	40 (1.6)
Height	mm (in)	250 (9.9)
Height without fixings	mm (in)	235 (9.3)
Depth	mm (in)	180 (7.1)
Weight	Kg (lb)	1.5 (3.3)
Case	IP	40
Storage Temperature	°C	-25...70
Operating Temperature	°C	0...50
Max. Case Temperature	°C	65

## Power Supply Requirement

### Power Supply motor

The calculation of the needed power for the Motor supply is depending on the application and the used motor.

### Power Supply signal

24VDC	min. 100mA	(no load on the outputs)
	typ. 1.1A	(all 10 outputs "on" with 100mA load and /Break with no load)
	max. 2.1A	(all 10 outputs "on" with 100mA load and /Break with 1A load)

## Regeneration of Power / Regeneration Resistor

There are two possibilities to deal with power regeneration:

- Option A: Connect an additional capacitor to the motor power supply. It is recommended to use a capacitor  $\geq 10'000 \mu\text{F}$  (install capacitor close to the power supply!)
- Option B: Install a Regeneration Resistor to X1 (RR+ and RR-). The threshold value of the voltage depends on the used motor voltage power supply. The max. threshold value must not exceed 88 Vdc.

Item	Description	Art. No.
Capacitor	Capacitor 10'000 $\mu\text{F}$ / 100 V	0150-3075
Regeneration Resistor	RR01-10/60 (10 Ohm, 60 W)	0150-3088
Regeneration Resistor	RR01-10/150 (10 Ohm, 150 W)	0150-3090

## Ordering Information

Servo Controller	Description	Art. No.
E1100-MP	Multi Position Controller 8 Commands 72VDC/4A	0150-1661
E1100-MP-HC	Multi Position Controller 8 Commands 72VDC/15A	0150-1662

**Declaration of Conformity CE-Marking**

Manufacturer: NTI AG  
 LinMot®  
 Haerdlistrasse 15  
 CH-8957 Spreitenbach  
 Switzerland  
 Tel.: +41 (0)56 419 91 91  
 Fax: +41 (0)56 419 91 92

Products: LinMot® Controllers

Type	Art.-No.	Type	Art.-No.	Type	Art.-No.
E1100-MP	0150-1661				
E1100-MP-HC	0150-1662				

The product must be mounted and used in strict accordance with the installation instruction contained within the User's Manual, a copy of which may be obtained from NTI Ltd.

I declare that as the authorized representative, the above information in relation to the supply/manufacture of this product is in conformity with the stated standards and other related documents in compliance with the protection requirements of the EMC Directive (89/336/EEC) and is marked in accordance with the CE Marking Directive (93/68/EEC).

Standards Complied with:

EMI	EN 55011	Class A
EN 61000-6-4		
Electromagnetic	EN 61000-4-2	4 kV / 8kV
Suspectibility EMC	EN 61000-4-4	1 kV / 2kV
EN 61000-6-2	EN 61000-4-3	10 V/m
	EN 61000-4-6	10 V
	ENV 50204	10 V/m

Company  
 NTI Ltd.

Zürich, June 29, 2004



-----  
 R. Rohner / CEO NTI Ltd.

## Error codes

In case of an error the following messages will be showed on the connected computer.

Error ID	Error Message
1	Logic supply voltage too low
2	Logic supply voltage too high
3	Motor supply voltage too low
4	Motor supply voltage too high
5	Regeneration Resistor not connected
10	Sensor Signals missing
13	Over Current
16	Servo Controller Ph1+ too Hot
17	Servo Controller Ph1- too Hot
18	Servo Controller Ph2+ too Hot
19	Servo Controller Ph2- too Hot
20	Servo Controller DCLV too Hot
22	Servo Controller Connector too Hot
23	Servo Controller Core too Hot
24	Servo Controller Power Bridge Ph1+ defect
25	Servo Controller Power Bridge Ph1- defect
26	Servo Controller Power Bridge Ph2+ defect
27	Servo Controller Power Bridge Ph2- defect
28	Servo Controller Supply DigOut IC Fuse Blow
29	Servo Controller Supply Motor 5VA Fuse Blow
30	Servo Controller Supply Motor AGND Fuse Blow
32	Motor Temp Sensor too hot
33	Motor Hall Signals missing
34	Motor Slider missing
35	Motor too hot calculated
36	Regeneration Resistor too hot calculated
40	Motor Ph1+ Short circuit to GND
41	Motor Ph1- Short circuit to GND
42	Motor Ph2+ Short circuit to GND
43	Motor Ph2- Short circuit to GND
44	Motor Short circuit Ph1 to Ph2
48	Wrong Wiring Motor Ph1+ To Ph2+
49	Wrong Wiring Motor Ph1+ To Ph2-
50	Wiring Broken Motor Ph1+ To Ph1-
51	Wrong Wiring Motor Ph2+ To Ph1+
52	Wrong Wiring Motor Ph2+ To Ph1-
53	Wiring Broken Motor Ph2+ To Ph2-
192	MPC data not found or defective!

**Contact Addresses**

**NTI AG**

LinMot  
Haerdlistrasse 15  
CH-8957 Spreitenbach  
Switzerland

Tel. +41 (0)56 419 91 91  
Fax. +41 (0)56 419 91 921  
email: [office@LinMot.com](mailto:office@LinMot.com)  
Web: [www.LinMot.com](http://www.LinMot.com)

**LinMot Inc.**

N2444 Broad Street  
Delavan  
WI 53115  
USA

Phone +1-877-546-3270 or 262-728-2699  
Fax: +1-800-463-8708 or 262-740-0141  
email: [officeUS@LinMot.com](mailto:officeUS@LinMot.com)  
Web: [www.LinMot.com](http://www.LinMot.com)

Smart solutions are...

