

# LinMot®



## MC-Link System

Installation Guide

***Eine Deutsche Version kann unter <http://www.linmot.com> bezogen werden!  
Please visit <http://www.linmot.com> to check for the latest version of this document!***

This document applies to the following controllers and drives:

B8050-ML-PL

B8050-ML-EC

B8050-ML-IP

B8050-ML-PN

B8050-ML-SC

B1150-ML(-HC, -XC)

© 2013 NTI AG

This work is protected by copyright.

Under the copyright laws, this publication may not be reproduced or transmitted in any form, electronic or mechanical, including photocopying, recording, microfilm, storing in an information retrieval system, not even for didactical use, or translating, in whole or in part, without the prior written consent of NTI AG.

LinMot® is a registered trademark of NTI AG.

The information in this documentation reflects the stage of development at the time of press and is therefore without obligation. NTI AG reserves itself the right to make changes at any time and without notice to reflect further technical advance or product improvement.

Document version 1.2.2 / Ro, December 2013

## Table of Content

<b>1 Installation Guide B1150-ML-xx</b> .....	<b>4</b>
1.1 Important Notes for B1150 Drives.....	4
1.2 System Overview.....	5
1.3 B1150-ML Interfaces.....	6
1.4 Functionality.....	7
1.5 Software.....	7
1.6 Power Supply and Grounding.....	8
1.7 Description of the connectors / Interfaces.....	9
1.7.1 X1.....	9
1.7.2 X2.....	9
1.7.3 X3.....	10
1.7.4 X13.....	11
1.7.5 X14.....	12
1.7.6 X21-X22.....	13
1.7.7 X23.....	13
1.7.8 S6.....	13
1.7.9 LED.....	13
1.8 MC-Link Termination Settings.....	14
1.9 Physical Dimension.....	14
1.10 Power Supply Requirement.....	15
1.11 Ordering Information.....	16
1.12 International Certifications.....	16
1.13 Declaration of Conformity CE-Marking.....	17
<b>2 Installation Guide B8050-ML-xx</b> .....	<b>18</b>
2.1 Important notes for B8000 series controllers.....	18
2.2 B8000 Interfaces.....	19
2.3 Functionality.....	20
2.4 MC-Link Multi-Axes Cabling.....	20
2.4.1 8 Axes System.....	21
2.4.2 4 Axes System.....	21
2.5 Power Supply and Grounding.....	22
2.6 Description of the connectors / Interfaces.....	23
2.6.1 X17-X18.....	23
2.6.2 X23.....	23
2.6.3 X24.....	23
2.6.4 X25 - X28.....	24
2.6.5 S1 - S2.....	24
2.6.6 LED.....	24
2.6.7 RT BUS LED.....	24
2.7 Physical Dimension.....	25
2.8 Power Supply Requirement.....	26
2.9 Ordering Information.....	26
2.10 International Certifications.....	26
2.11 Declaration of Conformity CE-Marking.....	27
<b>3 Contact Addresses</b> .....	<b>28</b>

## 1 Installation Guide B1150-ML-xx

### 1.1 Important Notes for B1150 Drives

#### CAUTION!



In order to assure a safe and error free operation, and to avoid severe damage to system components, all system components must be directly attached to a single ground bus that is earth or utility grounded.



Each system component should be tied directly to the ground bus (star pattern), rather than daisy chaining from component to component. (LinMot motors are properly grounded through their power cables when connected to LinMot drives).



All connectors must not be connected or disconnected while DC voltage is applied. Do not disconnect system components until all LinMot drives LEDs have turned off. (Capacitors in the power supply may not fully discharge for several minutes after input voltage has been disconnected). Failure to observe these precautions may result in severe damage to electronic components in LinMot motors and/or drives.



Do not switch Power Supply DC Voltage. All power supply switching and E-Stop breaks should be done to the AC supply voltage of the power supply.



Do not connect or disconnect the motors from drives while voltage is applied. Wait to connect or disconnect motors until all LinMot drives LEDs have turned off. (Capacitors may not fully discharge for several minutes after power has been turned off). Failure to observe these precautions may result in severe damage to electronic components in LinMot motors and/or drives.

## 1.2 System Overview

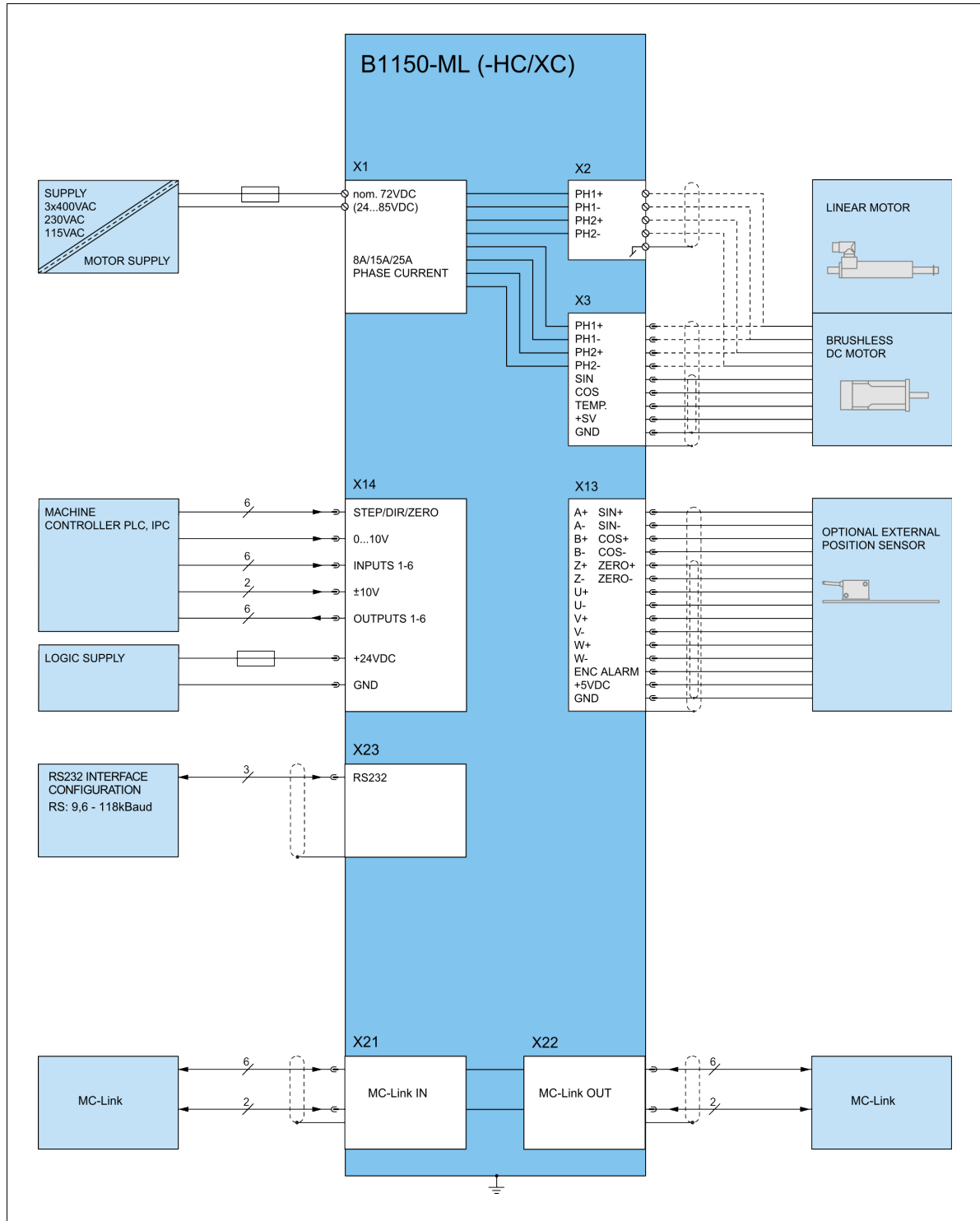

Typical servo system B1150-ML-xx: Drive, motor and power supply.

### 1.3 B1150-ML Interfaces

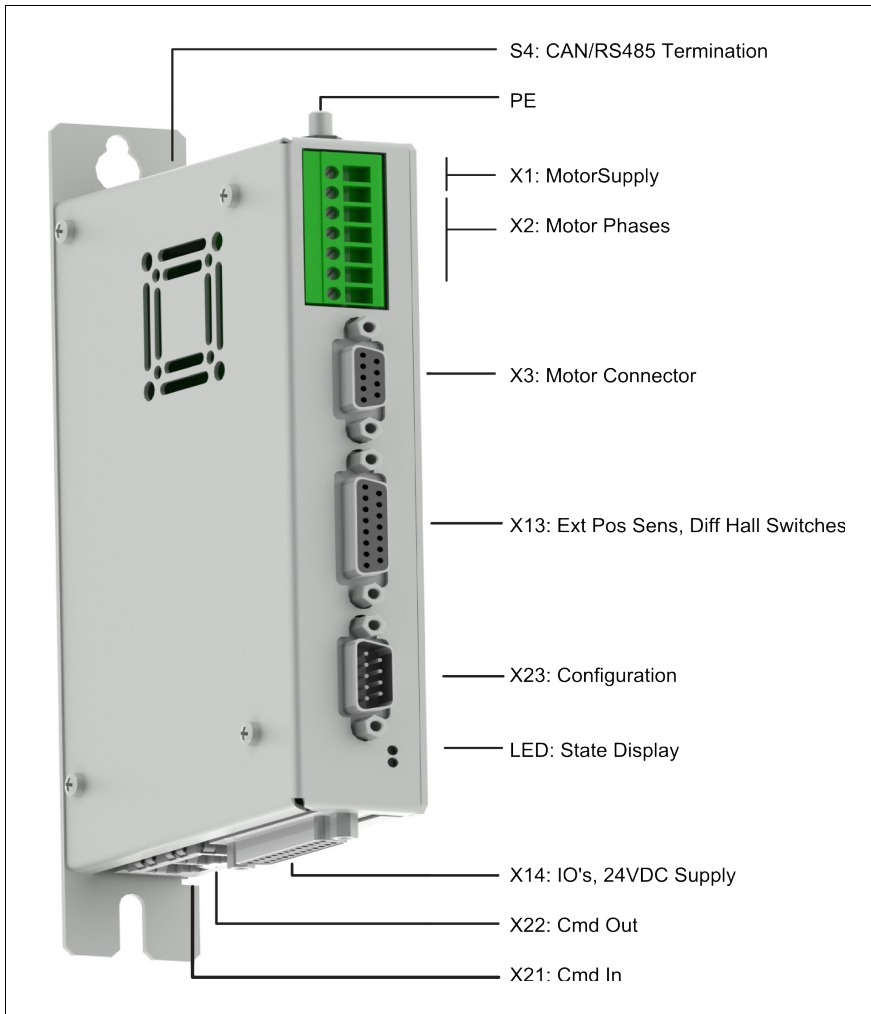

		B1150-ML-XX
Connector		
X1	Motor Supply	•
X2	Motor Phases (Screw Terminals)	•
X3	Motor / Motor Signals	•
X13	External/Simulated Position Encoder Diff Hall Switches	•
X14	6 Digital Inputs 6 Digital Outputs Analog In 0..10V Analog In -10V.. +10V Diff Step Dir zero 24V Logic Supply	•
X21	MC-Link In	•
X22	MC-Link Out	•
X23	Com / Config RS232	•
LED	State Indicator	•
S6	MC-Link Termination	•

## 1.4 Functionality

	B1150-ML	B1150-ML-HC	B1150-ML-XC
<b>Supply Voltage</b>			
Motor Supply 72VDC (24...85VDC)	•	•	•
Logic Supply 24VDC (22...26VDC)	•	•	•
<b>Motor Phase Current</b>			
8A <sub>peak</sub> / 6A <sub>rms</sub>	•		
15A <sub>peak</sub> / 9A <sub>rms</sub>		•	
25A <sub>peak</sub> / 12A <sub>rms</sub>			•
<b>Controllable Motors</b>			
LinMot P01-23x...	•	•	•
P01-37x...	•	•	•
P01-48x...	•	•	•
DC Motors	•	•	•
Brushless DC / EC Motors	•	•	•
<b>Command Interface</b>			
Easy Steps Max. 6 Commands	•	•	•
+/-10V Current Command Interface	•	•	•
Step Direction Indexer Interface	•	•	•
Cmd Tab IO Interface (X14-IOs) (with EasySteps)	•	•	•
MC-Link	•	•	•
<b>External Position Sensor</b>			
Incremental RS422 up to 2 MHz	•	•	•
<b>Position Indexer Input</b>			
Step Dir Zero/ ABZ RS422 up to 2 MHz	•	•	•
<b>Position Encoder Simulation</b>			
AB RS422 up to 2.5 MHz	•	•	•
<b>Configuration</b>			
RS232 Configuration	•	•	•
<b>MC-Link Bus-ID</b>			
Automatically obtained via Cable Select	•	•	•

## 1.5 Software

The configuration software LinMot-Talk is free of charge and can be downloaded from the LinMot homepage ([www.LinMot.com](http://www.LinMot.com)).

## 1.6 Power Supply and Grounding

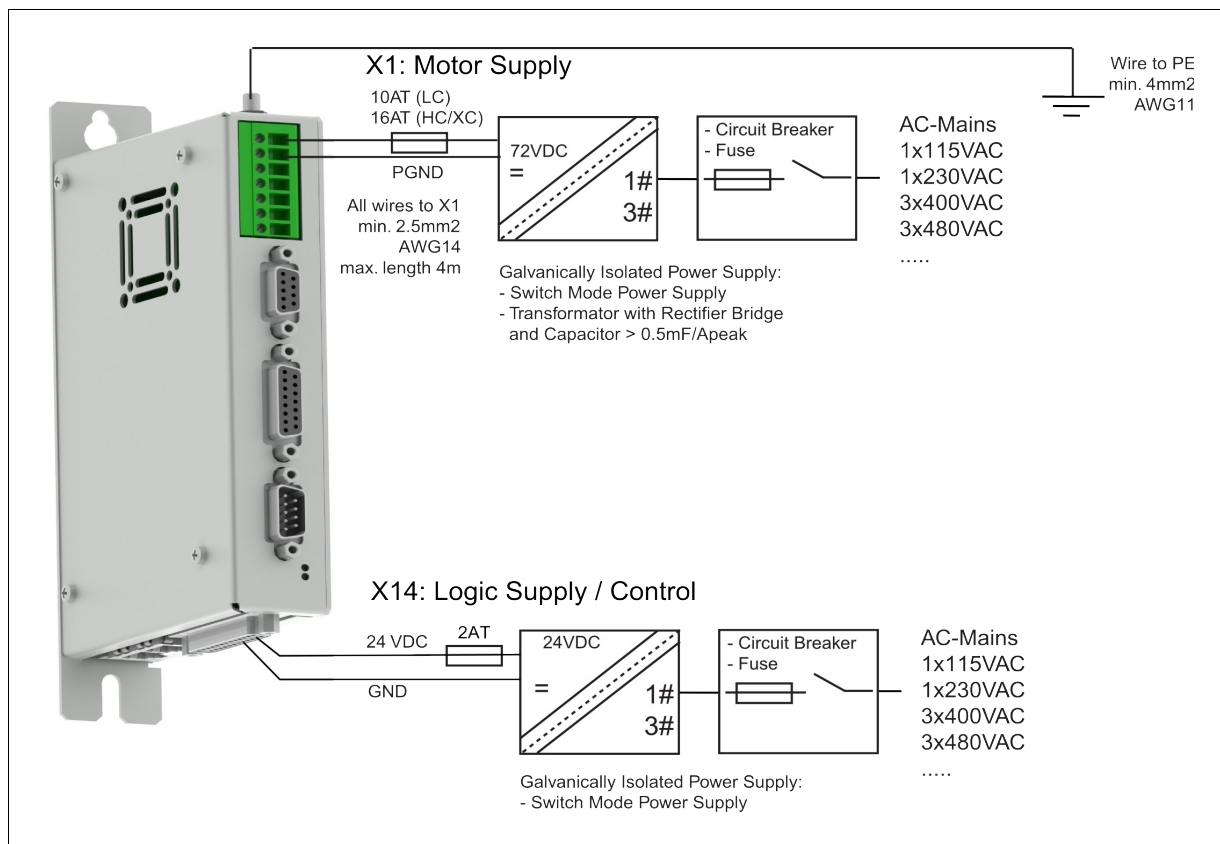

In order to assure a safe and error free operation and to avoid severe damage to system components, **all system components\* must be well grounded to either a single earth or utility ground.** This includes both LinMot and all other control system components to the same ground bus.



Each system component\* should be tied directly to the ground bus (**star pattern**), rather than daisy chaining from component to component. (LinMot motors are properly grounded through their power cables when connected to LinMot drives.)



**Power supply connectors must not be connected or disconnected while DC voltage is present.** Do not disconnect system components until all LinMot drives LEDs have turned off. (Capacitors in the power supply may not fully discharge for several minutes after input voltage has been disconnected). Failure to observe these precautions may result in severe damage to electronic components in LinMot motors and/or drives.



**Do not switch Power Supply DC Voltage.** All power supply switching and E-Stop breaks should be done to the AC supply voltage of the power supply. Failure to observe these precautions may result in severe damage to drive.

\* Inside of the B1150 drive the *PWR motor GND* and *PWR signal GND* is connected together and to the GND of the drive housing. It is recommended that the *PWR motor GND* is NOT grounded at another place than inside of the drive to avoid circular currents.



## 1.7 Description of the connectors / Interfaces

### 1.7.1 X1

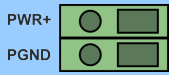
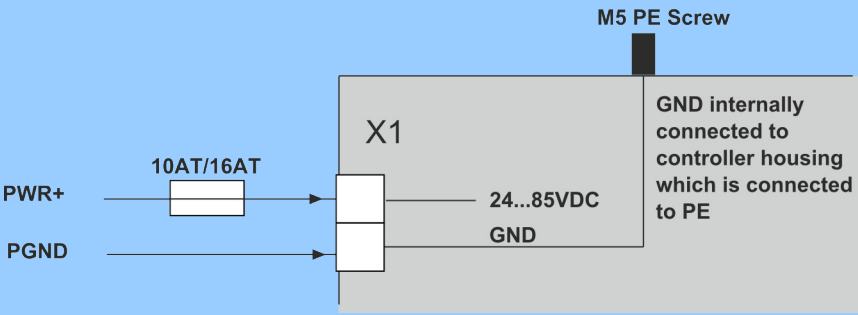
X1 Motor Supply	
 <p>PWR+</p> <p>PGND</p>	 <p>M5 PE Screw</p> <p>10AT/16AT</p> <p>PWR+</p> <p>PGND</p> <p>X1</p> <p>24...85VDC GND</p> <p>GND internally connected to controller housing which is connected to PE</p>
<p>Screw Terminals</p>	<p>Motor Supply: 72VDC nominal, 24...85VDC Absolute max. Rating: 72VDC +20%.</p> <p>External Fuse: 10AT for LC (8Apeak), 16AT for HC and XC (15A/25Apeak) servos.</p> <p>If motor supply voltage exceeds 90VDC, the drive will go into error state.</p> <ul style="list-style-type: none"> <li>- Tightening Torque: min 0.4Nm</li> <li>- Screw Thread: M 2,5</li> <li>- Use 60/75°C copper conductors only</li> <li>- Conductor Cross-Section 2.5mm<sup>2</sup> (AWG14) max Length 4m</li> </ul>

### 1.7.2 X2

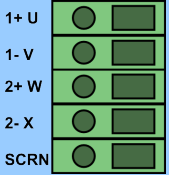
X2 Motor Phases				
 <p>1+ U</p> <p>1- V</p> <p>2+ W</p> <p>2- X</p> <p>SCRN</p>	<table border="0"> <tr> <td style="vertical-align: top;"> <p>PH1+ /U</p> <p>PH1- /V</p> <p>PH2+ /W</p> <p>PH2- /X</p> <p>SCRN</p> </td> <td style="vertical-align: top;"> <p><b>LinMot Motor:</b></p> <p>Motor Phase 1+ red</p> <p>Motor Phase 1- pink</p> <p>Motor Phase 2+ blue</p> <p>Motor Phase 2- grey</p> <p>Shield</p> </td> <td style="vertical-align: top;"> <p><b>3-phase EC-Motor:</b></p> <p>Motor Phase U</p> <p>Motor Phase V</p> <p>Motor Phase W</p> </td> </tr> </table>	<p>PH1+ /U</p> <p>PH1- /V</p> <p>PH2+ /W</p> <p>PH2- /X</p> <p>SCRN</p>	<p><b>LinMot Motor:</b></p> <p>Motor Phase 1+ red</p> <p>Motor Phase 1- pink</p> <p>Motor Phase 2+ blue</p> <p>Motor Phase 2- grey</p> <p>Shield</p>	<p><b>3-phase EC-Motor:</b></p> <p>Motor Phase U</p> <p>Motor Phase V</p> <p>Motor Phase W</p>
<p>PH1+ /U</p> <p>PH1- /V</p> <p>PH2+ /W</p> <p>PH2- /X</p> <p>SCRN</p>	<p><b>LinMot Motor:</b></p> <p>Motor Phase 1+ red</p> <p>Motor Phase 1- pink</p> <p>Motor Phase 2+ blue</p> <p>Motor Phase 2- grey</p> <p>Shield</p>	<p><b>3-phase EC-Motor:</b></p> <p>Motor Phase U</p> <p>Motor Phase V</p> <p>Motor Phase W</p>		
<p>Screw Terminals</p>	<p>The motor phases are present at X2 and X3. It is recommended to use X2. It is only allowed to use X3 for connecting motor phases if RMS current is below 2A and peak current is below 4A.</p> <p>Never connect motor phases on X2 and X3!</p> <ul style="list-style-type: none"> <li>- Tightening Torque: min 0.4Nm</li> <li>- Screw Thread: M 2,5</li> <li>- Conductor Cross-Section: max. 2.5mm<sup>2</sup></li> <li>- Use 60/75°C copper conductors only</li> </ul>			

1.7.3 X3

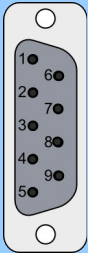
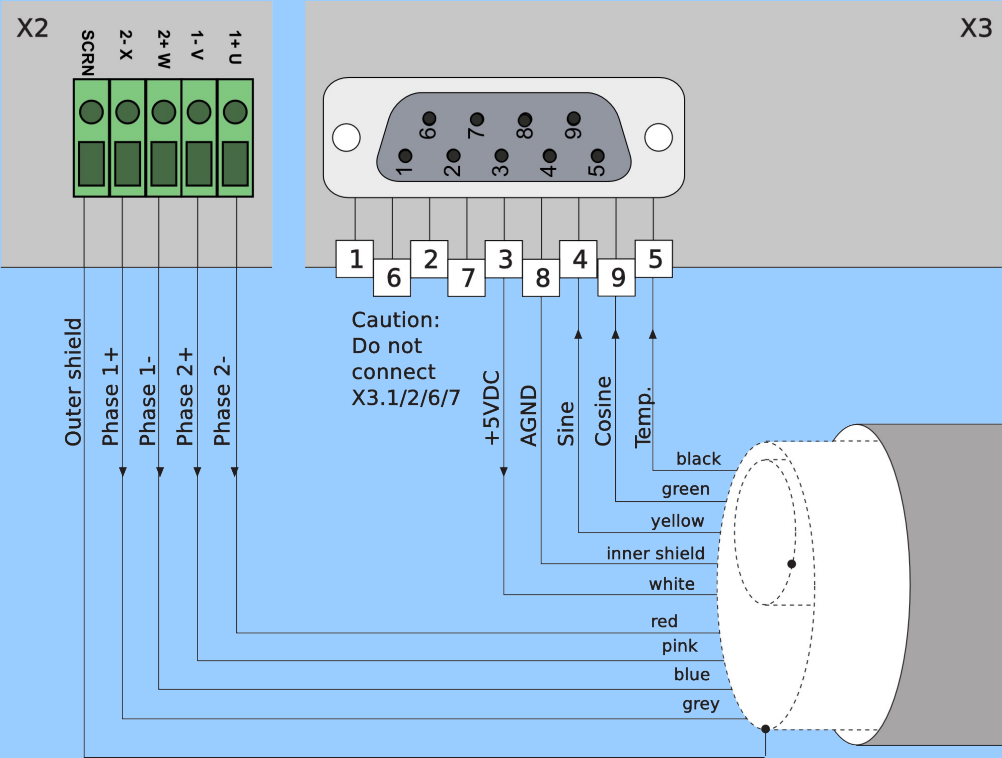
X3	Motor		
	<table border="0"> <tr> <td style="vertical-align: top;"> <b>LinMot Motor:</b>                      1 Motor Phase 1+                      2 Motor Phase 2+                      3 +5VDC                      4 Sensor Sine                      5 Temp. In                      6 Motor Phase 1-                      7 Motor Phase 2-                      8 AGND                      9 Sensor Cosine                      case Shield                 </td> <td style="vertical-align: top;"> <b>3-phase EC-Motor:</b>                       +5VDC (Hall Supply)                      Hall 1                      Hall 3                       AGND (Hall Supply)                      Hall 2                 </td> </tr> </table>	<b>LinMot Motor:</b> 1 Motor Phase 1+ 2 Motor Phase 2+ 3 +5VDC 4 Sensor Sine 5 Temp. In 6 Motor Phase 1- 7 Motor Phase 2- 8 AGND 9 Sensor Cosine case Shield	<b>3-phase EC-Motor:</b>  +5VDC (Hall Supply) Hall 1 Hall 3  AGND (Hall Supply) Hall 2
<b>LinMot Motor:</b> 1 Motor Phase 1+ 2 Motor Phase 2+ 3 +5VDC 4 Sensor Sine 5 Temp. In 6 Motor Phase 1- 7 Motor Phase 2- 8 AGND 9 Sensor Cosine case Shield	<b>3-phase EC-Motor:</b>  +5VDC (Hall Supply) Hall 1 Hall 3  AGND (Hall Supply) Hall 2		
DSUB-9 (f)	<p><u>Note:</u> Use +5V (X3.3) and AGND (X3.8) only for motor internal hall sensor supply (max. 100mA).</p> <p><u>Caution:</u> Do NOT connect AGND (X3.8) to ground or earth! It is only allowed to use X3 for connecting the motor phases if RMS current is below 2A and peak current below 4A.</p>		
<b>Motor Wiring for Phase Currents above 2A RMS or 4A peak (recommended general wiring)</b>			
	 <p><b>Caution:</b> Do not connect X3.1/2/6/7</p>		
	<p><b>Important:</b> If motor phase current exceeds <math>2A_{RMS}</math> or <math>4A_{peak}</math>, motor phases must be wired to X2!</p>		

Motor wiring for Phase Currents below 2A RMS and 4A peak

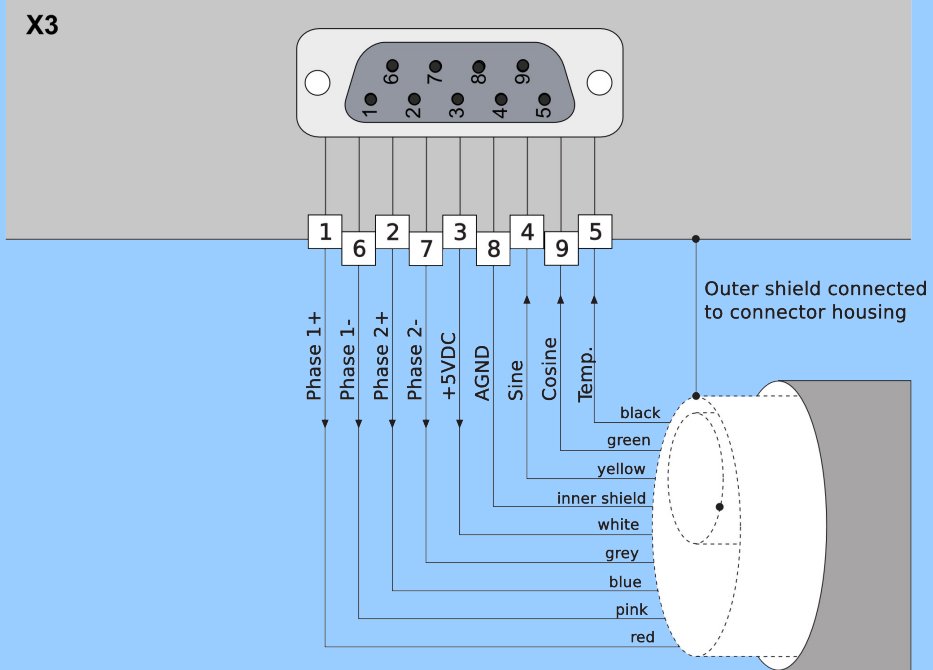

**Important:**

Motor phases may only be connected to X3 if RMS current is below 2A and peak current is below 4A!

**1.7.4 X13**

**X13 External Position Sensor Differential Hall Switches**

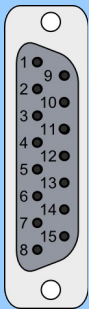

1	+5V DC
9	A+
2	A-
10	B+
3	B-
11	Z+
4	Z-
12	Encoder Alarm
5	GND
13	U+
6	U-
14	V+
7	V-
15	W+
8	W-
case	Shield

DSUB-15 (f)

Position Encoder Inputs (RS422):  
Max Input Frequency: 2MHz, 4 M counts/s with quadrature decoding, 240ns edge separation

Encoder Simulation Outputs (RS422):  
Max Output Frequency: 2.5MHz, 5 M counts/s with quadrature decoding, 200ns edge separation

Differential Hall Switch Inputs (RS422):  
Input Frequency: <1kHz

Enc. Alarm In:  
5V / 1mA

Sensor Supply:  
5VDC max 100mA

1.7.5 X14

X14

24VDC Supply and IOs

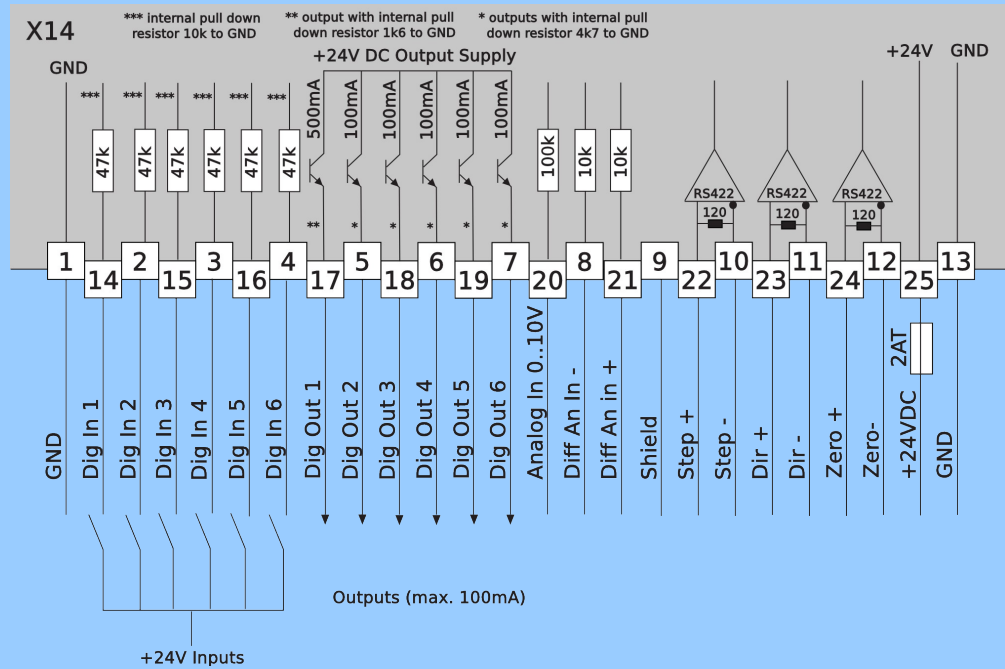
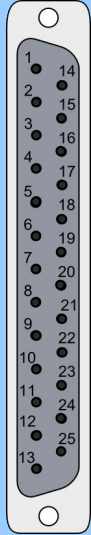

DSUB-25 (f)

**Logic Supply:**  
 Switch Mode Power Supply: 24VDC (22...26VDC)  
 External Fuse: 2AT

**All Digital Inputs:**  
 Direct interfacing to digital 24VDC PLC outputs.  
 Input Current: 1mA  
 Logic Levels: Low Level: guaranteed: -5 to 5VDC, typically < 8VDC  
 High Level guaranteed: 20...30VDC, typically > 16VDC  
 Sample Rate: 400us

**All Digital Outputs:**  
 Short circuit and overload protected high side switches.  
 Voltage: 24VDC  
 Update Rate: 400us  
 Max. Current: 100mA / 500mA for X14.17  
 Peak Current: 370mA / 1100mA for X14.17

Outputs may directly drive inductive loads. Do not connect any capacity because of the peak current!

**Analog Input on X14.20:**  
 Range: 0V..+10V 10Bit ADC  
 Sample Rate: 400us

**Differential Analog Input on X14.8 X14.21 X14.9 Shield:**  
 Range: -10V..+10V 10Bit ADC  
 Sample Rate: 400us

**Differential Step Dir Zero:**  
 Indexer Inputs: RS422, Max. Input Frequency: 2MHz, 4 M counts/s with quadrature decoding, 240ns edge separation

MC-Link Installation Guide

### 1.7.6 X21-X22

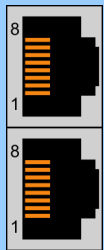
X21 - X22	MC-Link	
	<p>1 ML1+</p> <p>2 ML1-</p> <p>3 ML2+</p> <p>4 Cable Select</p> <p>5 GND</p> <p>6 ML2-</p> <p>7 ML3+</p> <p>8 ML3-</p> <p>case Shield</p>	
RJ-45	Use MC-Link cables (Art.-No. 0150-3308)	

### 1.7.7 X23

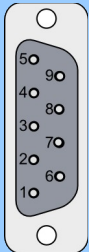
X23	RS Config	
	<p>1 (Do not connect)</p> <p>2 RS232_Tx</p> <p>3 RS232_Rx</p> <p>4 (Do not connect)</p> <p>5 GND</p> <p>6 (Do not connect)</p> <p>7 (Do not connect)</p> <p>8 (Do not connect)</p> <p>9 (Do not connect)</p> <p>case Shield</p>	
DSUB-9 (m)	RS232: Configuration on all drives: use 1:1 connection cable to PC with only Pins 2,3 and 5 connected. Use LinMot RS Config Cable (Art.-No. 0150-3307)	

### 1.7.8 S6

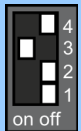
S6	MC-Link Termination	
	S6	<p>Switch 4: Bootstrap</p> <p>Switch 3: Termination A on/off</p> <p>Switch 2: Termination B on/off</p> <p>Switch 1: Not used</p> <p>Factory settings: Switch 3 "on", all other switches "off"</p>

### 1.7.9 LED

LED	State Display	
	<p>Green</p> <p>Red</p>	<p>24V Logic Supply OK</p> <p>Error</p>

## 1.8 MC-Link Termination Settings

Termination A (S6.3) has to be set on every B1150 drive of a MC-Link connection.

## 1.9 Physical Dimension

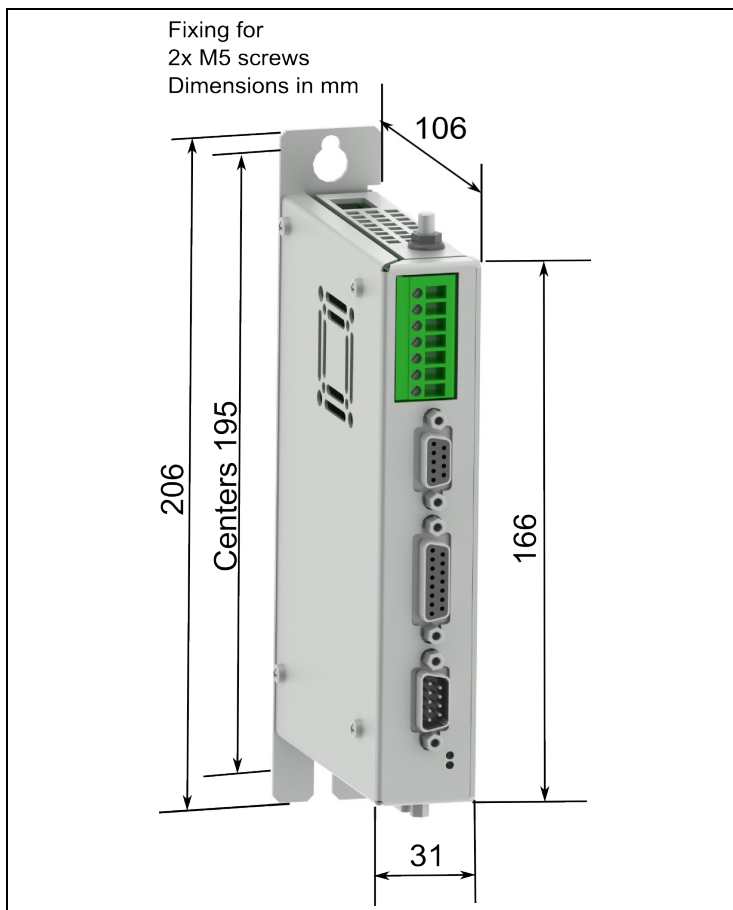

<b>B1150 Single axis drive</b>		
Width	mm (in)	31 (1.3)
Height	mm (in)	166 (6.6)
Height with fixings	mm (in)	206 (8.1)
Depth	mm (in)	106 (4.2)
Weight	g (lb)	700 (1.6)
Case	IP	20
Storage Temperature	°C	-25...40
Transport Temperature	°C	-25...70
Operating Temperature	°C	0...40 at rated data 40...50 with power derating
Relative humidity		95% (non-condensing)
Max. Case Temperature	°C	70
Max. Power Dissipation	W	30
Clearance around Drives	mm (in)	15 (0.8) left/right 50 (2) top 100 (4) bottom 90 (3.5) front

## 1.10 Power Supply Requirement

### Motor Power Supply

The calculation of the needed power for the motor supply depends on the application and the used motor. The nominal supply voltage is 72 VDC. The possible range is from 24 to 85 VDC.



**ATTENTION:** The motor supply can rise up to 95 VDC when braking. This means that everything connected to that power supply needs a voltage rating of 100 VDC. (Additional capacitors, etc...)



To provide short circuit power limitation, it is required to use an external fuse (10AT for blank labeled (LC) and 16AT for HC and XC labeled drives).

### Recommended Power supplies:

Item	Description	Art. No.
T01-72/420	72VDC, 15A peak, 420VA, 3x400VAC	0150-1966
T01-72/420-US	72VDC, 15A peak, 420VA, 3x230VAC	0150-1967
T01-72/900	72VDC, 30A peak, 900VA, 3x400VAC	0150-1842
T01-72/900-US	72VDC, 30A peak, 900VA, 3x230VAC	0150-1843
T01-72/1500	72VDC, 2x30A peak, 1500VA, 3x400VAC	0150-1844
T01-72/1500-US	72VDC, 2x30A peak, 1500VA, 3x230VAC	0150-1845
S01-72/500	72VDC, 500W, 750W peak, 1x100..120VAC/200..240VAC	0150-1874
S01-72/1000	72VDC, 1000W, 2000W peak, 3x380..500VAC	0150-1872

### Signal Power Supply

The logic supply needs a regulated power supply with a nominal voltage of 24 VDC. The voltage must be between 22 and 26 VDC.

### Current Consumption

Min. 200mA (no load on the outputs)  
 Typ. 0.5A (all 6 outputs "on" with 50mA load and /Break with no load)  
 Max. 1.2A (all 6 outputs "on" with 100mA load and /Break with 0.5A load)



**To limit the power in case of malfunction, it is required to use an external fuse (2AT)!**

## 1.11 Ordering Information

Servo Drive	Description	Art. No.
B1150-ML	MC-Link Drive 72VDC / 8A	0150-1796
B1150-ML-HC	MC-Link Drive 72VDC / 15A	0150-1797
B1150-ML-XC	MC-Link Drive 72VDC / 25A	0150-1798
Accessories	Description	Art. No.
RS232 Config Cable	AC01-Df/Df-2-RS1 RS232 Config Cable DSUB9 f/f 2m (2-2/3-3/5-5)	0150-3307
MC-Link Cable	AC01-RJ45/RJ45-0.2-ML1 MC-Link Cable 0.2m	0150-3308

## 1.12 International Certifications

Certifications	
Europe 	See chapter "1.13 Declaration of Conformity CE-Marking"



### 1.13 Declaration of Conformity CE-Marking

Manufacturer: NTI AG *LinMot*®  
 Haerdlistrasse 15  
 8957 Spreitenbach  
 Switzerland  
 Tel.: +41 (0)56 419 91 91  
 Fax: +41 (0)56 419 91 92

Products: *LinMot*® Drives

Type	Art.-No.	Type	Art.-No.	Type	Art.-No.
B1150-ML	0150-1796				
B1150-ML-HC	0150-1797				
B1150-ML-XC	0150-1798				

The product must be mounted and used in strict accordance with the installation instruction contained within the Installation Guide, a copy of which may be obtained from NTI Ltd.

I declare that as the authorized representative, the above information in relation to the supply/manufacture of this product is in conformity with the stated standards and other related documents in compliance with the protection requirements of the Electromagnetic Compatibility (EMC) Directive 2004/108/EC.

Standards Complied with:

EN 61000-6-2		Immunity for industrial environment	
	EN 61000-4-2	Class B	Electrostatic discharge immunity (ESD)
	EN 61000-4-3	Class A	Radiated electromagnetic field immunity
	EN 61000-4-4	Class B	Fast transients / burst immunity (EFT)
	EN 61000-4-5	Class B	Slow transients immunity (Surges)
	EN 61000-4-6	Class A	Conducted radio frequency immunity
EN 61000-6-4		Emission for industrial environment	
	EN 55022	Class A	Radiated Emission

Company  
 NTI Ltd.

Spreitenbach, September 07, 2010



-----  
 R. Rohner / CEO NTI AG

## 2 Installation Guide B8050-ML-xx

### 2.1 Important notes for B8000 series controllers

#### CAUTION!



In order to assure a safe and error free operation, and to avoid severe damage to system components, all system components must be directly attached to a single ground bus that is earth or utility grounded (see chapter Power Supply and Grounding).



Each system component should be tied directly to the ground bus (star pattern), rather than daisy chaining from component to component. (see chapter Power Supply and Grounding).



All connectors must not be connected or disconnected while DC voltage is applied. Do not disconnect system components until all LinMot controller LEDs have turned off. (Capacitors in the power supply may not fully discharge for several minutes after input voltage has been disconnected). Failure to observe these precautions may result in severe damage to electronic components in LinMot motors and/or controllers.



Do not switch Power Supply DC Voltage. All power supply switching and E-Stop breaks should be done to the AC supply voltage of the power supply.

2.2 B8000 Interfaces

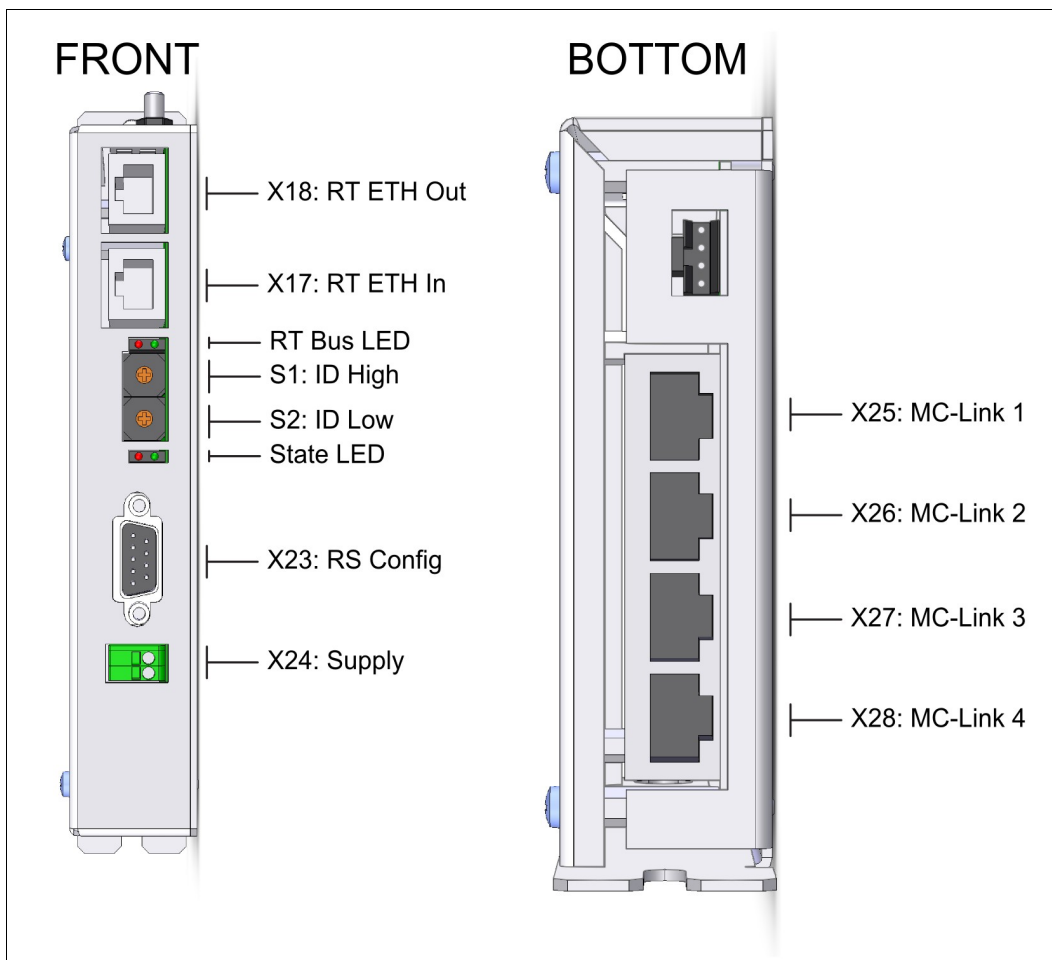

MC-Link Installation Guide

		B8050-ML-XX
Connector		
X17	RT ETH In	•
X18	RT ETH Out	•
X23	RS Config	•
X24	Supply	•
X25	MC-Link 1	•
X26	MC-Link 2	•
X27	MC-Link 3	•
X28	MC-Link 4	•
RT Bus LED	RT Bus Indicator	•
State LED	State Indicator	•
S1	ID Switch High	•
S2	ID Switch Low	•

## 2.3 Functionality

	B8050-ML-PL	B8050-ML-PN	B8050-ML-SC	B8050-ML-IP	B8050-ML-EC
<b>Supply Voltage</b>					
Logic Supply 24VDC (22...26VDC)	•	•	•	•	•
<b>Command Interface</b>					
POWERLINK	•				
PROFINET		•			
SERCOS III			•		
ETHERNET IP				•	
ETHERCAT					•
<b>Motion Interface</b>					
MC-Link	•	•	•	•	•
<b>Configuration Interface</b>					
RS232	•	•	•	•	•

## 2.4 MC-Link Multi-Axes Cabling



All components of a MC-Link system must be referenced to the same ground! The same 24VDC supply must be used for all components!



Use only LinMot MC-Link cable (Art.-No. 0150-3308) to connect MC-Link devices! Longer cables must not be used!



For configuration via RS232 use 1:1 connection cable to PC with only Pins 2, 3 and 5 connected!  
Use LinMot RS Config Cable (Art.-No. 0150-3307).



Cabling has to be done exactly as depicted in this chapter!  
Do not connect more than two devices per MC-Link connector!

### 2.4.1 8 Axes System

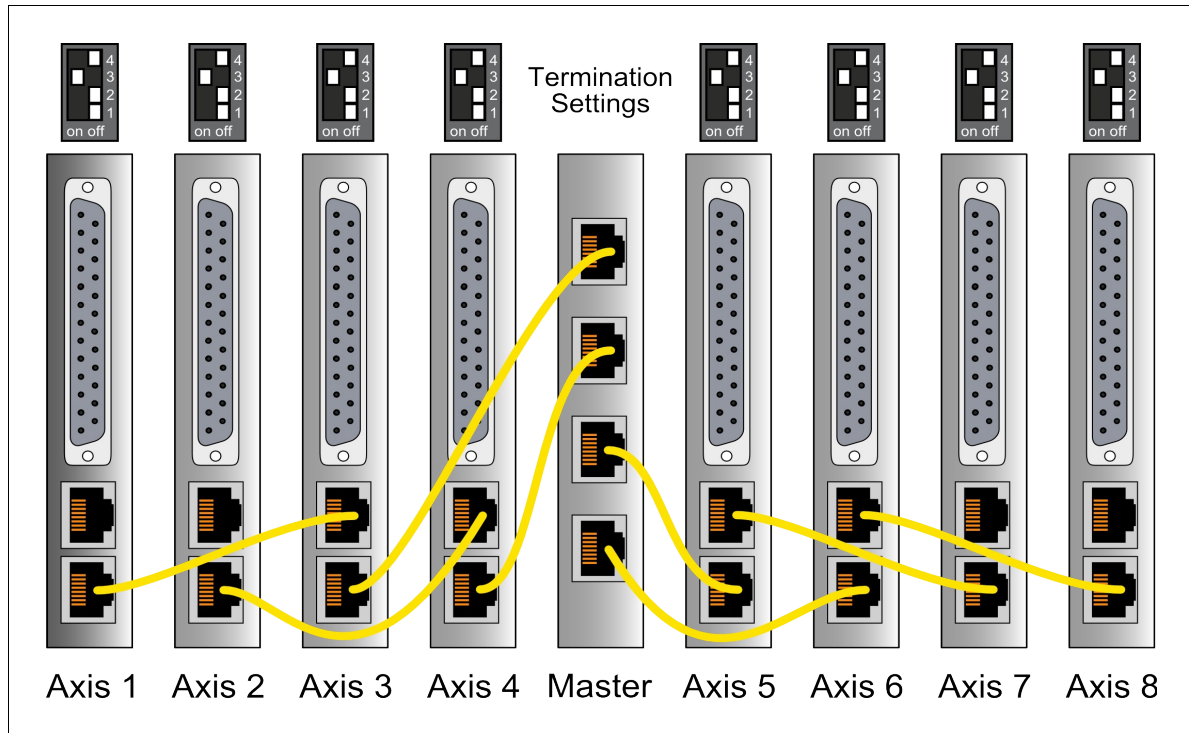

### 2.4.2 4 Axes System

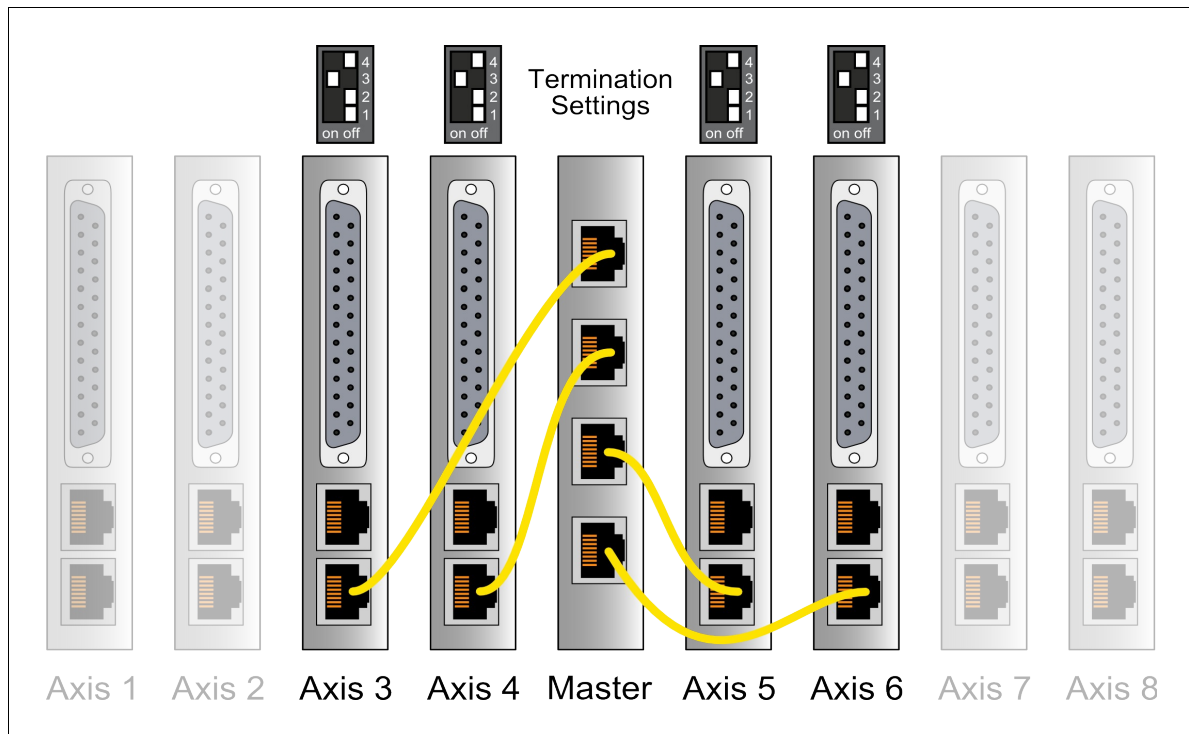

## 2.5 Power Supply and Grounding

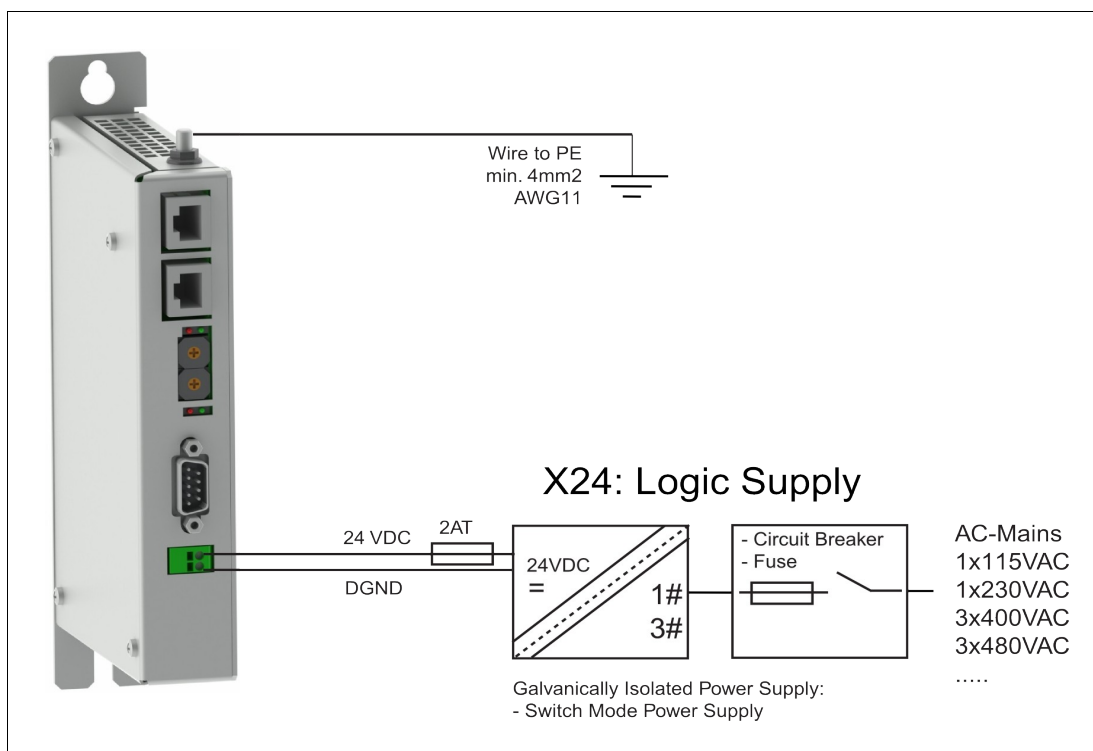

In order to assure a safe and error free operation, and to avoid severe damage to system components, **all system components must be well grounded to either a single earth or utility ground.** This includes both LinMot and all other control system components to the same ground bus.



Each system component should be tied directly to the ground bus (**star pattern**), rather than daisy chaining from component to component.



**Power supply connectors must not be connected or disconnected while DC voltage is present.** Do not disconnect system components until all LinMot controller LED's have turned off. (Capacitors in the power supply may not fully discharge for several minutes after input voltage has been disconnected). Failure to observe these precautions may result in severe damage to electronic components in LinMot motors and/or controllers.



**Do not switch Power Supply DC Voltage.** All power supply switching and E-Stop breaks should be done to the AC supply voltage of the power supply. Failure to observe these precautions may result in severe damage to controller.

## 2.6 Description of the connectors / Interfaces

### 2.6.1 X17-X18

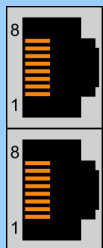
X17 - X18		RealTime Ethernet 10/100Mbit/s
	X17 RT ETH In	Specification depends on RT-Bus type. Please refer to according documentation.
	X18 RT ETH Out	

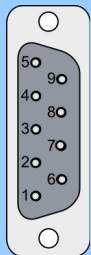

### 2.6.2 X23

X23		RS Config
	1 (Do not connect) 2 RS232_Tx 3 RS232_Rx 4 (Do not connect) 5 GND 6 (Do not connect) 7 (Do not connect) 8 (Do not connect) 9 (Do not connect) case Shield	RS232: Configuration on all controllers: use 1:1 connection cable to PC with only Pins 2,3 and 5 connected. Use LinMot RS Config Cable (Art.-No. 0150-3307)
	DSUB-9 (m)	

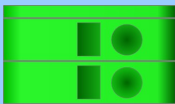

### 2.6.3 X24

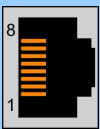
X24		Supply
	2 +24VDC Supply (22 – 26VDC) 1 GND Supply	Supply 24V / typ. 150mA - Stripping Length: 10mm - Connection in acc. with standard: EN-VDE - Use 60/75°C copper conductors only - Conductor cross-section max. 1.5mm <sup>2</sup>
	Phoenix, SPT 1,5/2-H-3,5	

## 2.6.4 X25 - X28

X25 - X28		MC-Link 1 (X25) / MC-Link 2 (X26) / MC-Link 3 (X27) / MC-Link 4 (X28)	
	<ul style="list-style-type: none"> <li>1 MLConn 1</li> <li>2 MLConn 2</li> <li>3 MLConn 3</li> <li>4 MLConn 4</li> <li>5 MLConn 5</li> <li>6 MLConn 6</li> <li>7 MLConn 7</li> <li>8 MLConn 8</li> </ul> case Shield		
RJ-45		<p><b>Use only LinMot MC-Link cable 0.2m for cabling! (0150-3308)</b>  <b>Longer cables must not be used!</b></p> <p>All devices, which are connected to X25 / X26 / X27 / X28 must be referenced to the same ground!</p>	

## 2.6.5 S1 - S2

S1 - S2		Address Selectors	
	S1	Bus ID High (0 ... F)	
	S2	Bus ID Low (0 ... F)	
The use of these switches depends on the type of fieldbus which is used. Please see the corresponding manual for further information.			

## 2.6.6 LED

LED	State Display	
	Green Red	24V Logic Supply OK Error

## 2.6.7 RT BUS LED

RT Bus LED	RT Bus State Display	
	Green Red	OK Error
The use of these LEDs depends on the type of fieldbus which is used. Please see the corresponding manual for further information.		



## 2.7 Physical Dimension

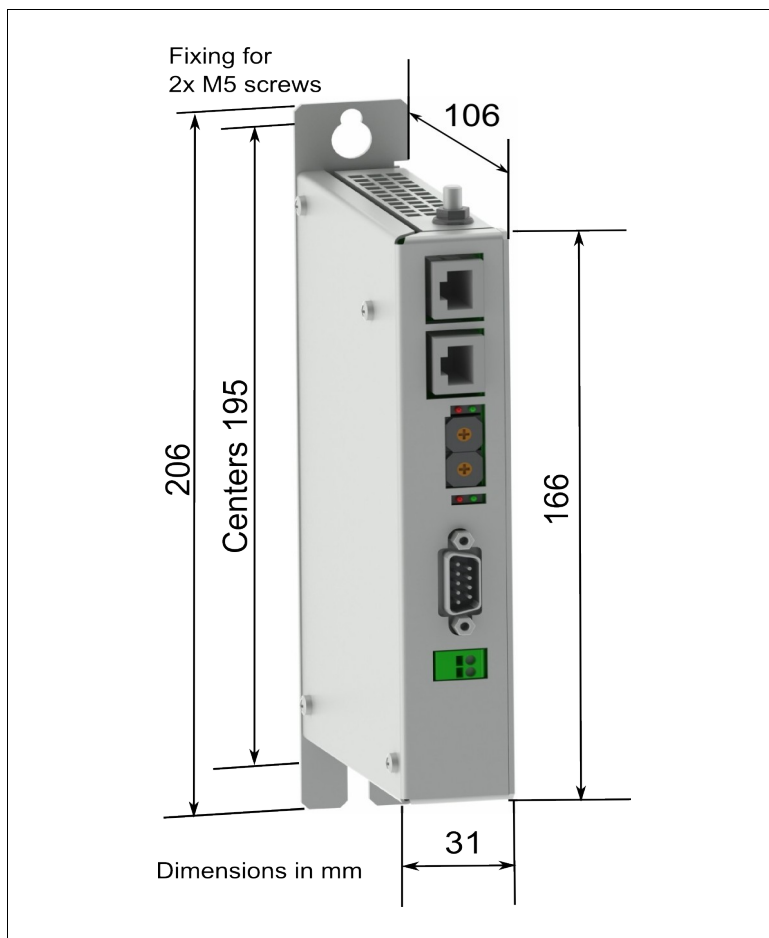

<b>B8000 Series MC-Link controller</b>		
Width	mm (in)	31 (1.3)
Height	mm (in)	166 (6.6)
Height with fixings	mm (in)	206 (8.1)
Depth	mm (in)	106 (4.2)
Weight	g (lb)	650 (1.5)
Case	IP	20
Storage Temperature	°C	-25...40
Transport Temperature	°C	-25...70
Operating Temperature	°C	0...40 at rated data
Relative humidity		95% (non-condensing)
Max. Case Temperature	°C	70
Max. Power Dissipation	W	6
Clearance around Controllers	mm (in)	15 (0.8) left/right 50 (2) top 100 (4) bottom 90 (3.5) front

## 2.8 Power Supply Requirement

### Signal Power Supply

The logic supply needs a regulated power supply with a nominal voltage of 24 VDC. The voltage must be between 22 and 26 VDC.

### Current Consumption

Min. 100mA  
**Typ. 150mA**  
 Max. 250mA

## 2.9 Ordering Information

Controller	Description	Art. No.
B8050-ML-PL	POWERLINK MC-Link Master	0150-1877
B8050-ML-EC	ETHERCAT MC-Link Master	0150-1878
B8050-ML-IP	ETHERNET IP MC-Link Master	0150-1879
B8050-ML-PN	PROFINET MC-Link Master	0150-1880
B8050-ML-SC	SERCOS III MC-Link Master	0150-1881
Accessories	Description	Art. No.
RS232 Config Cable	AC01-Df/Df-2-RS1	0150-3307
	RS232 Config Cable DSUB9 f/f 2m (2-2/3-3/5-5)	
MC-Link Cable	AC01-RJ45/RJ45-0.2-ML1	0150-3308
	MC-Link Cable 0.2m	

## 2.10 International Certifications

Certifications	
Europe 	See chapter "2.11 Declaration of Conformity CE-Marking"

## 2.11 Declaration of Conformity CE-Marking

Manufacturer: NTI AG *LinMot*®  
 Haerdlistrasse 15  
 8957 Spreitenbach  
 Switzerland  
 Tel.: +41 (0)56 419 91 91  
 Fax: +41 (0)56 419 91 92

Products: *LinMot*® Controllers

Type	Art.-No.	Type	Art.-No.	Type	Art.-No.
B8050-ML-PL	0150-1877	B8050-ML-PN	0150-1880		
B8050-ML-EC	0150-1878	B8050-ML-SC	0150-1881		
B8050-ML-IP	0150-1879				

The product must be mounted and used in strict accordance with the installation instruction contained within the Installation Guide, a copy of which may be obtained from NTI Ltd.

I declare that as the authorized representative, the above information in relation to the supply/manufacture of this product is in conformity with the stated standards and other related documents in compliance with the protection requirements of the Electromagnetic Compatibility (EMC) Directive 2004/108/EC.

Standards Complied with:

EN 61000-6-2		Immunity for industrial environment	
	EN 61000-4-2	Class B	Electrostatic discharge immunity (ESD)
	EN 61000-4-3	Class A	Radiated electromagnetic field immunity
	EN 61000-4-4	Class B	Fast transients / burst immunity (EFT)
	EN 61000-4-5	Class B	Slow transients immunity (Surges)
	EN 61000-4-6	Class A	Conducted radio frequency immunity
EN 61000-6-4		Emission for industrial environment	
	EN 55022	Class A	Radiated Emission

Company  
 NTI Ltd.

Spreitenbach, September 07, 2010



-----  
 R. Rohner / CEO NTI AG

### 3 Contact Addresses

**SWITZERLAND****NTI AG**

Haerdlistr. 15  
CH-8957 Spreitenbach

**Sales and Administration:** +41-(0)56-419 91 91  
office@linmot.com

**Tech. Support:** +41-(0)56-544 71 00  
support@linmot.com

**Tech. Support (Skype) :** skype:support.linmot

**Fax:** +41-(0)56-419 91 92  
**Web:** http://www.linmot.com/

**USA**

**LinMot, Inc.**  
204 E Morrissey Dr.  
Elkhorn, WI 53121

**Sales and Administration:** 877-546-3270  
262-743-2555

**Tech. Support:** 877-804-0718  
262-743-1284

**Fax:** 800-463-8708  
262-723-6688

**E-Mail:** us-sales@linmot.com  
**Web:** http://www.linmot-usa.com/

Please visit <http://www.linmot.com/> to find the distributor closest to you.

Smart solutions are...

