

SMB60 - 1.4 Nm

(LAYOUT 2IB - 2ID)

Tolleranze generali : UNI ISO 2768 - f
General Tolerances :

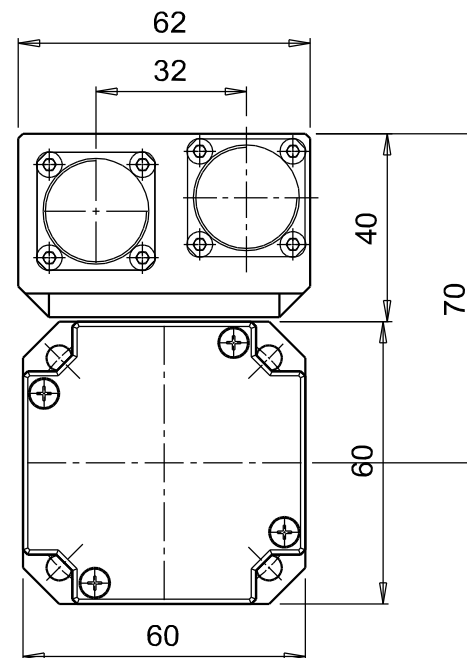
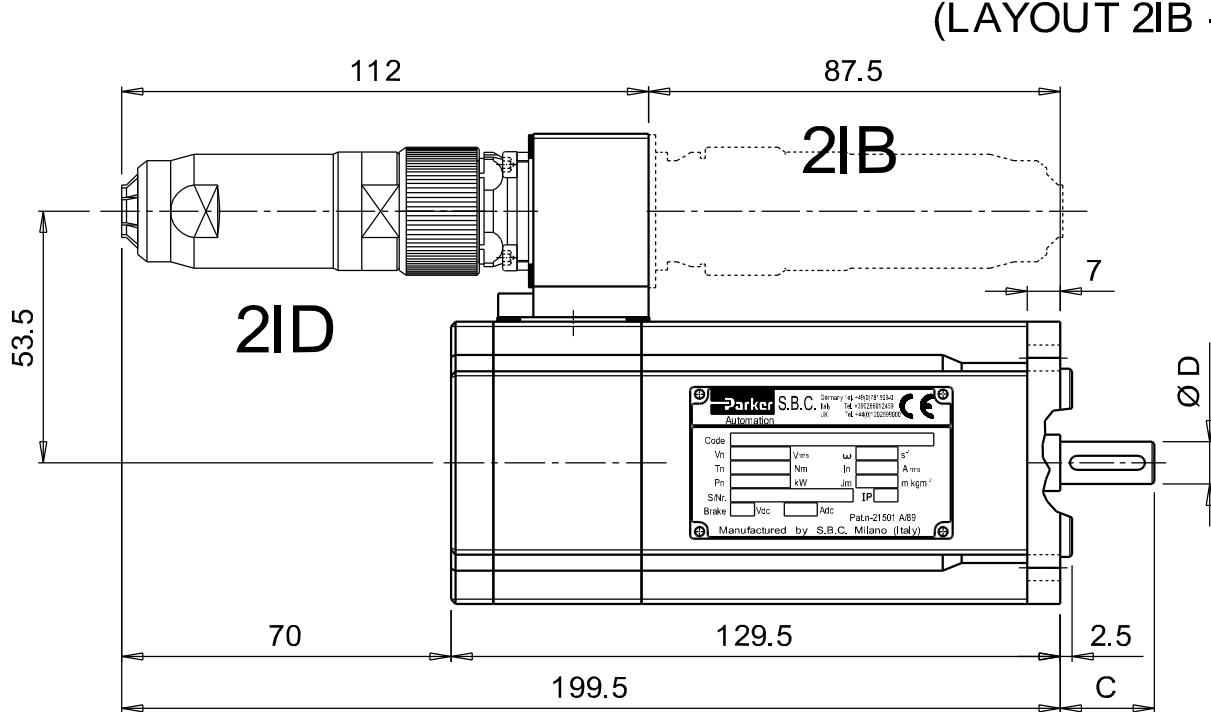

FLANGE (CODE)

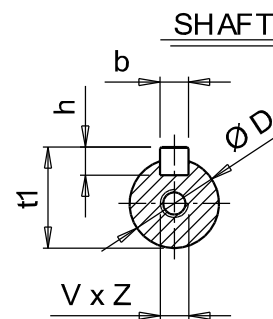
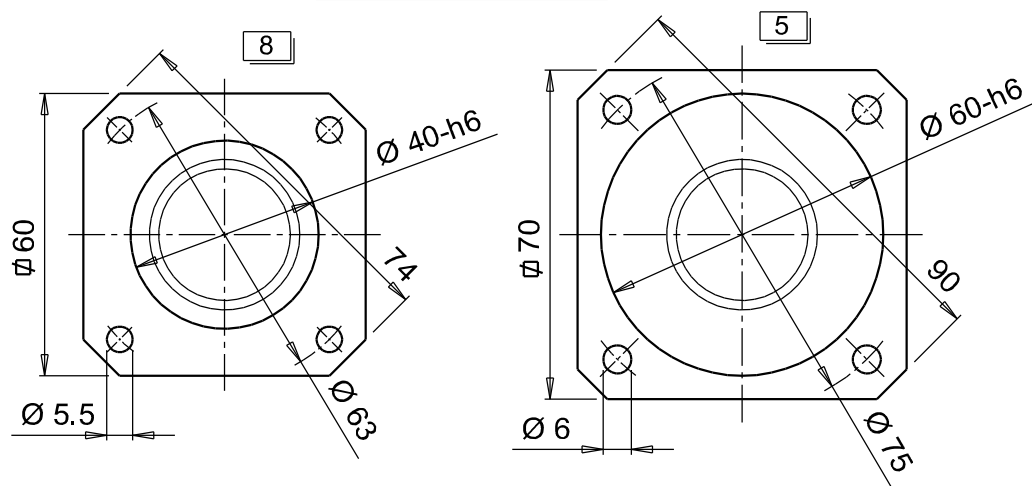

SHAFT DIMENSIONS						
Pos.*	C x D	b x h	t1	V x Z		
1	20 9	3 3	10.2	n.d.		
2	23 11	4 4	12.5	M4	10	

* It is the shaft id. number required for the motor ordering. If followed by "S" letter means shaft without key.

Modifiche / Revisions	Ref.	Data / Date	Rev.	Descrizione / Description	Eseg. / Esec.	Control. / Check
5	--	--	--			
4	--	--	--			
3	--	--	--			
2	--	--	--			
1	--	--	--			

	Parker Hannifin S.p.A. Divisione S.B.C.	Scala/Scale	Data / Date	Firma / Sign.
		-	16/11/01	
Via Gounod, 1 - Tel. +39 02 66012459 20092 Cinisello Balsano (MI) - ITALY		Disegn. Drawing Contr. Check Modif.to Modify	16/11/01	REV. 0
Descrizione : DIMENSIONS Tipo : SMB 60 - 1.4 Nm (LAYOUT 2I) Type :		Dis N° QISMB60\D2I Draw N°		
File :		Codice Code -		

Disegni, specifiche e dati contenuti in questo documento o riferimenti su questo disegno sono di proprietà della Divisione SBC, Parker Hannifin S.p.A. e non possono essere riprodotti, realizzati o utilizzati senza autorizzazione scritta della stessa. Drawings, specifications and details contained on or referenced on this drawing are proprietary to the SBC Division, Parker Hannifin S.p.A. and may not be reproduced, manufactured, or otherwise used without the written consent by the same.