



Trio Motion Technology Ltd.
Shannon Way, Tewkesbury,
Gloucestershire. GL20 8ND
United Kingdom
Tel: +44 (0)1684 292333
Fax: +44 (0)1684 297929

1000 Gamma Drive
Suite 206
Pittsburgh, PA 15238
United States of America
Ph: +1 412.968.9744
Fx: +1 412.968.9746

MC224 Preliminary Technical Reference Data

Motion Coordinator MC224

Overview The *Motion Coordinator* MC224 is Trio's most powerful modular servo control positioner with the ability to control up to 24 servo or stepper motors in any combination by the insertion of "Axis Daughter Boards" to suit the application. It is housed in a rugged metal chassis and incorporates all the isolation circuitry necessary for direct connection to external equipment in an industrial environment. Filtered power supplies are included so that it can be powered from the 24V d.c. logic supply present in most industrial cabinets.

It is designed to be configured and programmed for the application using a PC running the *Motion Perfect* application software, and then may be set to run "standalone" if an external computer is not required for the final system.

The Multi-tasking version of Trio BASIC for the MC224 allows up to 14 Trio BASIC programs to be run simultaneously on the controller using pre-emptive multi-tasking.

! SAFETY WARNING !

During the installation and use of a control system, users of Trio products must ensure there is no possibility of injury to any person, or damage to machinery.

Control systems, especially during installation, can malfunction or behave unexpectedly. Bearing this in mind, users must ensure that even in the event of a malfunction or unexpected behaviour the safety of an operator or programmer is never compromised.



Programming The Multi-tasking ability of the MC224 allows parts of a complex application to be developed, tested and run independently, although the tasks can share data and motion control hardware.

I/O Capability The MC224 has 8 built in 24v inputs and 8 bi-directional I/O channels. These may be used for system interaction or may be defined to be used by the controller for end of travel limits, datuming and feedhold functions if required. Each of the Input/Output channels has a status LED to make it easy to check them at a glance. The MC224 can have up to 512 external Input/Output channels connected using DIN rail mounted CAN 16-I/O modules. These units connect to the built-in CAN channel.

Communications The MC224 has two built in RS-232 ports and has provision for an external duplex RS-485 channel for simple factory communication systems. The TRIO fibre optic network system can be fitted as an option.

One of the RS-232 ports may be configured to run the MODBUS protocol for PLC or HMI interfacing. If the built-in CAN channel is not used for connecting I/O modules, it may optionally be used for CAN communications.

Ethernet, CANbus and Profibus daughter boards may be fitted to provide additional communications options.

Axis Positioning Functions The motion control generation software receives instructions to move an axis or axes from the Trio BASIC language which is running concurrently on the same processor. The motion generation software provides control during operation to ensure smooth, coordinated movements, velocity profiled as specified by the controlling program. Linear interpolation may be performed in as many axes as the controller provides, and circular or helical interpolation in any two orthogonal axes. Each axis may run independently or they may be linked in any combination using interpolation, CAM profile or the electronic gearbox facilities.

Consecutive movements may be merged to produce continuous path motion and the user may program the motion using programmable units of measurement (e.g. mm, inches, revs etc.). The module may also be programmed to control only the axis speed. The positioner checks the status of end of travel limit switches which can be used to cancel moves in progress and alter program execution.

Connections to the MC224

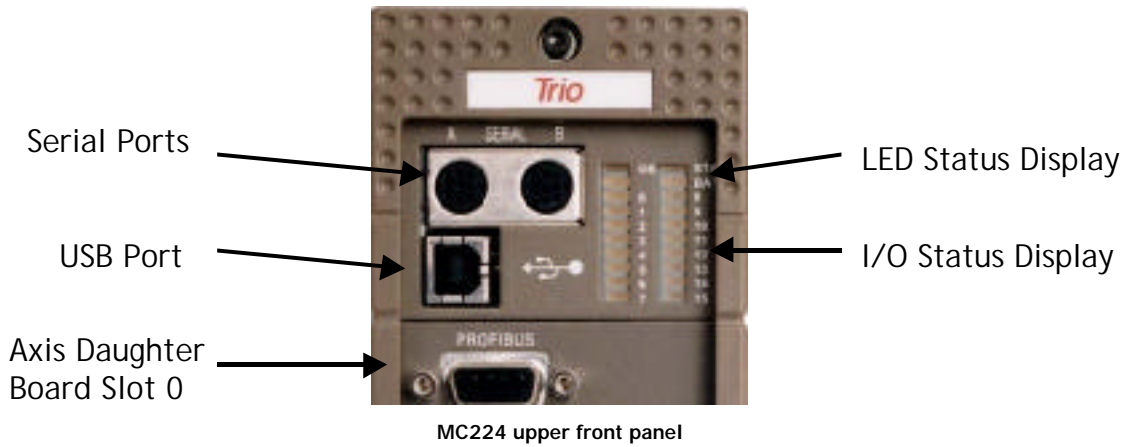

MC224 Serial Connections

The MC224 features two serial connectors. Both ports feature a standard RS-232 serial interface. The lower connector (port 1) also has connections for RS-485 multi-drop (addresses as port 2).

Port 0 is the default connection between the *Motion Coordinator* and the host PC running *Motion Perfect* for programming. *Motion Perfect* may also be connected via USB with the optional (P295) USB Daughter Board

Serial Cables

Trio recommend the use of their pre-made serial cables (product code P350). If cables need to be made to connect to a PC serial port the following connections are required:



Motion Coordinator to 'AT' style PC with 9pin serial connector

Serial Connector A:



Pin	Function	Note
1	Internal 5V	
2	Internal 0V	
3	RS232 Transmit	Serial Port 0
4	RS232 Ground	
5	RS232 Receive	
6	+5V Output	
7	Externally Buffered Output (TTL)	For Fibre-Optic Adapter
8	Externally Buffered Input (TTL)	
Note: Port 0 is the default programming port for connection to the PC running <i>Motion Perfect</i> .		

Serial Connector B:



Pin	Function	Note
1	RS485 Data in A	Serial Port 2
2	RS485 Data in B	
3	RS232 Transmit	Serial Port 1
4	RS232 Ground	
5	RS232 Receive	
6	Internal 5V	Serial Port 2
7	RS485 Data out Z	
8	RS485 Data out Y	

There is no hardware handshake on the serial ports. An XON\XOFF protocol is used.

Universal Serial Bus



USB port provides a high-speed universal serial bus link to a PC or other supporting USB.

port can be used for a high-speed connection to *Motion Perfect*, or to a program on the PC via Trio's ActiveX component

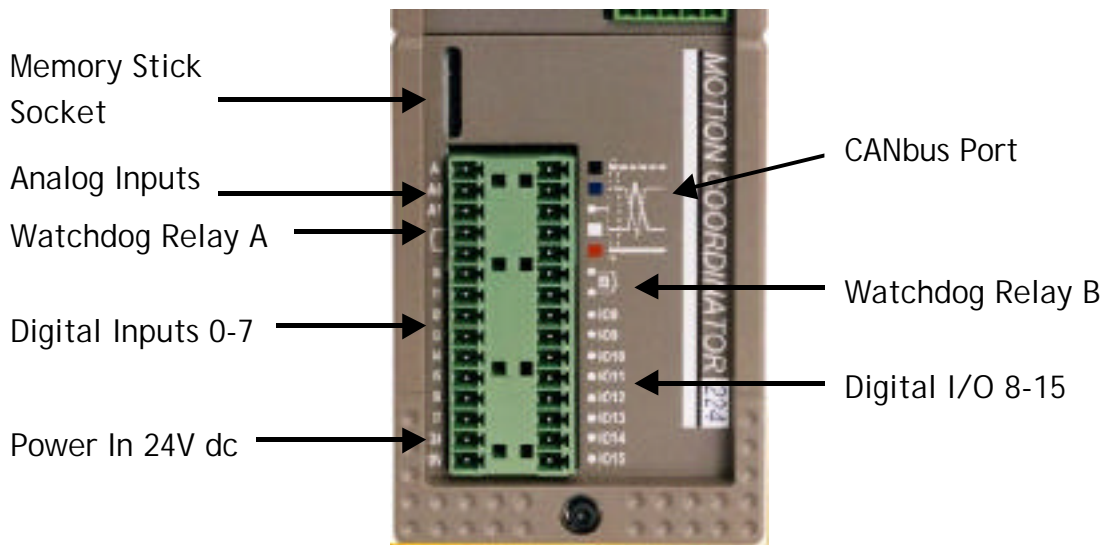

MC224 lower front panel

24v Power Supply Input

The MC224 is powered entirely via the 24v d.c. supply connections. The unit uses internal DC-DC converters to generate independent 5v logic supply, the encoder 5v supply and other internal power supplies.

Amplifier Enable (Watchdog) Relay Output

Two internal relay contacts are used to enable external amplifiers when the controller has powered up correctly and the system and application software is ready. The amplifier enable is a single pole relay with a set of normally open contacts. The enable relay contact will be open circuit if there is no power on the controller OR a following error exists on a servo axis OR the user program sets it open with the WDOG=OFF command. The amplifier enable relay may, for example, be incorporated within a hold-up circuit or chain that must be intact before a 3-phase power input is made live.

Relay A and Relay B normally open and close together but they also can be programmed to control two separate groups of axes. Contact Trio for information about the software release required for this function.

Note: ALL STEPPER AND SERVO AMPLIFIERS MUST BE INHIBITED WHEN THE AMPLIFIER ENABLE OUTPUT IS OPEN CIRCUIT

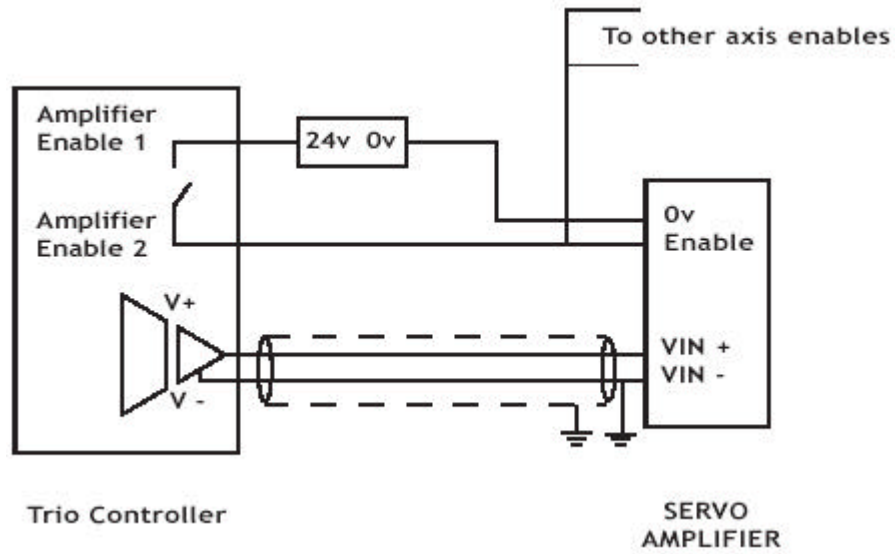

Amplifier Enable Output

CAN Bus:

The MC224 features a built-in CAN channel. This is primarily intended for Input/Output expansion via Trio's P315 and P325 modules. It may be used for other purposes when I/O expansion is not required.

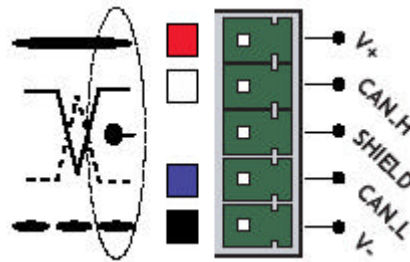

24v Input Channels

The *Motion Coordinator* has 16 24v Input channels built into the master unit. These may be expanded to 256 Inputs by the addition of CAN-16 I/O modules.

All of the 24v input channels have the same circuit although 8 on the master unit have 24v Output channels connected to the same pin. These bi-directional channels may be used for Input or Output to suit the application. If the channel is to be used as an input, then the output should not be switched on in the program.

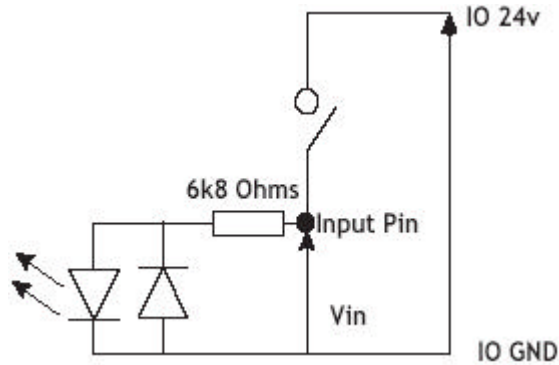

24v I/O Channels

Input/output channels 8..15 are bi-directional. The inputs have a protected 24v sourcing output connected to the same pin. If the output is unused it may be used as an input in the program. The input circuitry is the same as on the dedicated inputs. The output circuit has electronic over-current protection and thermal protection which shuts the output down when the current exceeds 250mA.

Care should be taken to ensure that the 250mA limit for the output circuit is not exceeded, and that the total load for the group of 8 outputs does not exceed 1 amp.

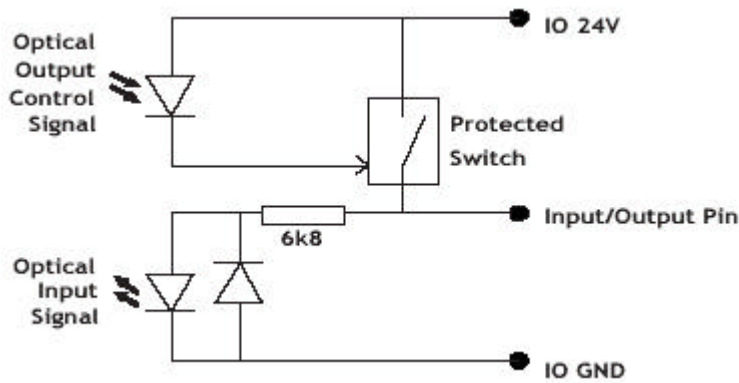

MC224 – Feature Summary

Size	262 mm x 68 mm x 198 mm (HxWxD)
Weight	0.75 Kg.
Operating Temperature	0 - 45 degrees C.
Control Inputs	Forward Limit, Reverse Limit, Datum Input, Feedhold Input.
Communication Ports	(2) RS232 channels: up to 38400 baud. (1) RS485 channel built-in. (1) Serial Adapter port. USB Port 12 Mbit/sec. CANbus port. (DeviceNet compatible)
Memory	1 Mbyte battery backed RAM. 1 Mbyte TABLE memory. Flash EPROM program storage.
Memory Stick	Socket for plug-in "Nextflash Mediastick". Can be used to store programs and/or data.
Programming	Multi-tasking TRIO BASIC system, maximum 14 user tasks.
Servo Cycle	Programmable: 1 msec, 500 usec or 250 usec.
Position Resolution	32 bit position count.
Speed Resolution	32 bits. Speed may be changed at any time. Moves may be merged.
Interpolation Modes	Linear 1 - 24 axes, circular, helical, CAM Profiles, speed control, electronic gearboxes.
Amplifier Enable Output	2 N.O. solid-state relays rated 24V ac/dc nominal. Maximum load 100 mA. Maximum voltage 29V.
Digital Inputs	16 Opto-isolated 24V Inputs.
Digital Outputs	8 Opto-isolated 24V Outputs. (Terminals shared with upper 8 Inputs)
Analog Inputs	2 x 12-bit 0 to 10V.
Power Supply	18 ... 29V d.c.

The material in this document is provisional and subject to change without notice. Despite every effort, in a document of this scope errors and omissions may occur. Therefore Trio Motion Technology cannot be held responsible for any malfunctions or loss of data as a result.

All goods supplied by Trio are subject to Trio's standard terms and conditions of sale.