

# ServoOne

Specification

## Option 2 - Technology

TTL Encoder Simulation /  
TTL Master Encoder





## Specification Option 2 - Technology

*TTL encoder simulation / TTL master encoder*

ID No: 1306.21B.1-00

Date: 02/2011

This documentation applies to:

Series	Model	Hardware version	Firmware version
ServoOne Single axis system 	SO82.xxx.0xx2 SO84.xxx.0xx2	from ...2.xxxx.2 from ...2.xxxx.2	all
ServoOne Multi axis system 	SO84.xxx.1xx2	from ...2.xxxx.2	all
ServoOne junior 	SO22.xxx.xxx2 SO24.xxx.xxx2	from ...2.xxxx.1 from ...2.xxxx.1	from V1.10



**NOTE:** This document does not replace the ServoOne junior Operation Manual. Please be sure to observe the information contained in the "For your safety", "Intended use" and "Responsibility" sections of the Operation Manual. For information on installation, setup and commissioning, and details of the warranted technical characteristics of the ServoOne junior, refer to the additional documentation (Operation Manual, User Manual, etc.).

### We reserve the right to make technical changes.

The content of our Operation Manual was compiled with the greatest care and attention, and based on the latest information available to us.

We should nevertheless point out that this document cannot always be updated in line with ongoing technical developments in our products.

Information and specifications may be subject to change at any time. Please visit [www.lt-i.com](http://www.lt-i.com) for the latest version.

# Table of Contents

- 1.1 Operation modes: .....4
- 1.2 Technical data .....4
  - 1.2.1 Voltage supply for external encoders .....4
  - 1.2.2 Cable type and layout .....5
- 1.3 Pin assignment .....5
- 1.4 Configuration .....6
  - 1.4.1 Configuration of TTL encoder simulation and repeater mode .....6
  - 1.4.2 Configuration TTL encoder channel X8 .....7
  - 1.4.3 Zero pulse wiring test .....8
  - 1.4.4 Interface configuration of encoder for loop control .....9

# TTL Module

## 1.1 Operation modes:

- Evaluation of a TTL encoder
- Simulation of a TTL encoder (signals from other encoders are converted into TTL signals and made available as output signals [for a slave axis])
- TTL repeater (evaluation and transmission of incoming TTL signals for additional axes)
- Simultaneous evaluation and simulation of a TTL encoder

## 1.2 Technical data

### TTL Signal evaluation

		Specification	
Interface	<ul style="list-style-type: none"> <li>• Differential voltage input, RS422-compatible; Pay attention to voltage range!</li> <li>• Max. cable length: 10 m</li> <li>• Connector: 15-pin D-SUB, High-Density, female</li> <li>• Surge terminating impedance built-in to device: 120 Ω</li> </ul>		
	min.	max.	type
Input frequency	0 Hz	500 kHz	
Input voltage			
Differential switching level "High"	+ 0.1 V		
Differential switching level "Low"		-0.1 V	
Signal level referred to ground	0	+ 5 V	

Table 1.1 TTL encoder input on X8

### TTL encoder simulation

		Specification	
Interface	<ul style="list-style-type: none"> <li>• RS422-compliant</li> <li>• Electrically isolated from the drive controller</li> <li>• Connector: 15-pin D-SUB, High-Density, female</li> </ul>		
	min.	max.	type
Output frequency	0 Hz	1000 kHz	
Output voltage			
Signal level referred to ground	0 V	+ 5 V	
Differential output voltage IUI	2.0 V	5 V	Surge terminating impedance ≥ 100 Ω

Table 1.2 TTL encoder simulation on X8

## 1.2.1 Voltage supply for external encoders

		Specification	
	min.	max.	type
Output voltage	+ 4.75 V	+ 5.25 V	+ 5 V
Output current	250 mA		

Table 1.3 Electrical specification of voltage supply for external encoders on X8



**ATTENTION:** No provision is made for connection of sensor cables to compensate for the voltage drop. So the chosen supply cable cross-section should take account of the voltage drop.



**NOTE:** The encoder supply on X8/3 is short-circuit-proof.

## 1.2.2 Cable type and layout

The cable type should be chosen as specified by the motor/encoder manufacturer.

### Recommended:

- TTL signal evaluation: 3 x 2 x 0.14 mm<sup>2</sup> and 1 x 2 x 0.5 mm<sup>2</sup>
- TTL encoder simulation: 4 x 2 x 0.14 mm<sup>2</sup>

### The following conditions must be met:

- Use only shielded cables.
- Shield on both sides.
- Interconnect the differential track signals A, B and R by twisted cable strands.
- Do not separate the encoder cable, for example to route the signals via terminals in the switch cabinet.

## 1.3 Pin assignment

The assignment of the 15-pin D-Sub female connector on slot X8 is set out in the following table.

Connection	TTL encoder			TTL encoder simulation		
	Pin	Signal	Comments	Pin	Signal	Comments
	1	A-	Track A-	1		
	2	A+	Track A+	2		
	3	+5V	Encoder supply	3		
	4			4	A+	Track A+
	5			5	A-	Track A-
	6	B-	Track B-	6		
	7			7	R+	Zero pulse +
	8	GND	+ 5 V reference potential	8		
	9	R-	Zero pulse -	9		
	10	R+	Zero pulse +	10		
	11	B+	Track B+	11		
	12			12	R-	Zero pulse -
	13			13	GND	Ground, required for potential equalization
	14			14	B+	Track B+
	15			15	B-	Track B-

Table 1.4 Anschlussbelegung des TTL-Moduls an X8

## 1.4 Configuration

### 1.4.1 Configuration of TTL encoder simulation and repeater mode

The TTL module can simulate a TTL encoder with the aid of encoder simulation. In this, the encoder simulation forms incremental encoder-compatible pulses from the position of the rotary encoder connected to the motor. Two 90° offset signals are generated on tracks A and B as well as a zero pulse (track R) (see figure 1.1). The lines per revolution of the encoder simulation can be set over a range from 0 to 65535 by way of P 2621.

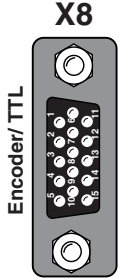
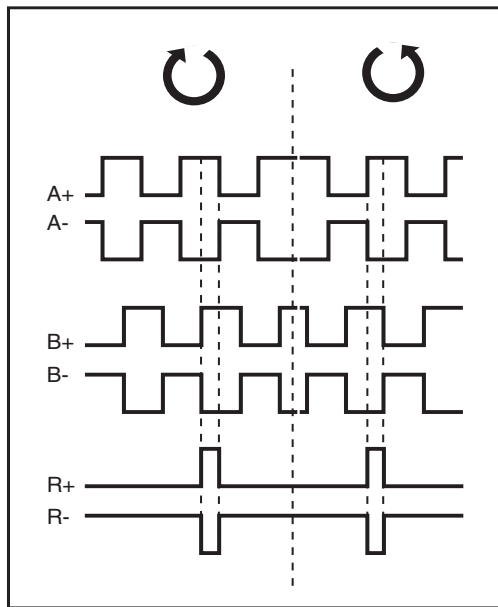

Figure 1.1 Encoder simulation signals looking towards the motor shaft

In repeater mode (only TTL signals can be evaluated) the TTL signal connected to X7 or X8 is outputted as a floating signal by way of encoder simulation. The signal delay of the repeater function is  $< 2 \mu\text{s}$ .

Parameter no.	Setting	Designation in DM5	Function
2825	Encoder simulation (1) to (5) Repeater mode (6), (7)	EncSimSel	Configuration of signal selection
(0)	Off	Off	Off
(1)	Act.Pos	Actual position	Actual position
(2)	Act.Pos.Inv	Actual position inverse	Actual position, inverted
(3)	Ref.Pos	Reference position	Position reference
(4)	Ref.Pos.Inv	Reference position inverse	Reference position, inverted
(5)	Virtual Master	Virtual Master	Virtual position of the module
(6)	Repeater X7	Repeater mode X7	Repeater mode active, TTL input signals on X7/8 are outputted without taking into account the preset lines per revolution in parameter P 2621 by way of encoder simulation.
(7)	Repeater X8	Repeater mode X8	
P 2621	0...65535 lines	EncSimLines	Configuration of lines per revolution for encoder simulation
P 2622	0...65535	EncSimIndexPulse	Position of the zero pulse scaled to 216 per revolution (360°)

Table 1.5 Selector settings

Lines per revolution	Encoder simulation rpm	Master encoder input rpm
8192	6000	3000
16384	3660	1830
32768	1830	915

Table 1.6 Rotation speeds for high lines per revolution (max. signal frequency)

## 1.4.2 Configuration TTL encoder channel X8

### Signal sources:

- TTL encoder with zero pulse
- Master encoder signal with two 90° offset track signals A/B
- Pulse/direction signal e.g from a stepper motor control

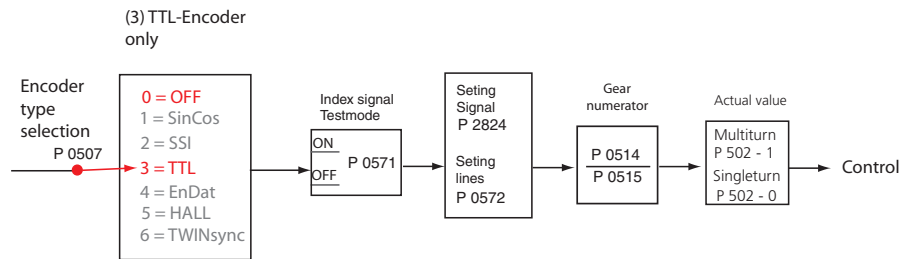

Figure 1.2 Configuration encoder channel X8

Parameter no.	Setting	Designation in DM5	Function
P 0502		ENC_CH3_ActVal	Actual value parameter: Raw data of single-turn and multi-turn information to test encoder evaluation.
(0)	00...00hex	Singleturn	The raw data are displayed after the electronic gearing and before the scaling (see figure 1.2); unit: increments.
(1)	00...00hex	Multiturn	
P 0507		ENC_CH3_Sel	Selection of encoder
(0)	OFF	No function	Off
(1)	SinCos encoder	SinCos	<b>Function not supported</b>
(2)	SSI encoder	SSI	
(3)	TTL encoder	TTL	TTL encoder with zero pulse
(4)	EnDat	ENDAT	<b>Function not supported</b>
(5)	TTL encoder with commutation signals	HALL	<b>Function not supported</b>
(6)	TWINSync	TWINSync	<b>Function not supported</b>
P 0514	$-(2^{31}) \dots + (2^{31}-1)$	ENC_CH3_Num	Numerator of encoder gearing
P 0515	$1 \dots (2^{31}-1)$	ENC_CH3_Denom	Denominator of encoder gearing
P 0571		ENC_CH3_NpTest	Zero pulse wiring test (more details following)
(0)	OFF	No function	No function
(1)	ON	ENABLE_ISR	Zero pulse test mode active
P 0572	Input of number of lines per revolution 1...65536	ENC_CH3_Lines	Setting of number of lines (max. 65536) of TTL encoder per motor revolution
P 2824	siehe Table 1.8	ENC_CH3_TTL_SignalType	TTL signal type

Table 1.7 Basic setting of encoder channel

Setting	Function	Example
AF_B (0)	<ul style="list-style-type: none"> <li>TTL signals (track A, track B)</li> <li>Direction of rotation of "slave axis" equal to "master axis"</li> </ul>	
AR_B (1)	<ul style="list-style-type: none"> <li>TTL signals (track A, track B)</li> <li>Direction of rotation of "slave axis" in inverse proportion to "master axis"</li> </ul>	
ABDFN (2)	<ul style="list-style-type: none"> <li>Pulse-direction signals (track A: puls; track B: direction)</li> <li>With a rising edge of track B positive direction</li> <li>Only falling edges of track A are evaluated.</li> </ul>	
ABDRP (3)	<ul style="list-style-type: none"> <li>Pulse-direction signals (track A: puls; track B: direction)</li> <li>With a falling edge of track B negative direction</li> <li>Only rising edges of track A are evaluated.</li> </ul>	

Table 1.8 Function description – parameter P 2824 (SignalType)

### 1.4.3 Zero pulse wiring test

To enable evaluation for the wiring test parameter **P 0571 = ON (1)** is set. On the oscilloscope it can then be depicted with the measurement variables **CH3-Np**. To make the zero pulse clearly visible, the measurement variable remains at High level until the next zero pulse appears. Conversely, the measurement variable remains at Low level until another zero pulse appears. In this, the pulse width of the scope signal does not match the pulse width of the actual zero pulse.

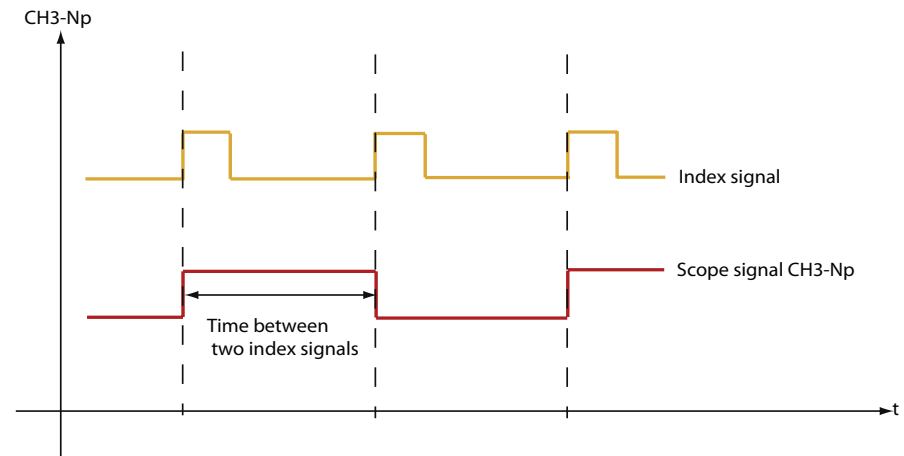

Figure 1.3 Zero pulse recording via measurement variable CH3-NP



NOTE: In zero pulse test mode zero pulse evaluation of homing runs is disabled.



### 1.4.4 Interface configuration of encoder for loop control

By way of P 0520, P 0521, P 0522 the physical encoder interface is adapted to the current, speed or position controller (see figure 1.4).

Parameter no.	Setting	Designation in DM5	Function
P 0520		ENC_MCon: Encoder: Channel Select for Motor Commutation and Current control	Selection of encoder channel for commutation angle and current control. Feedback signal for field-oriented regulation.
P 0521		ENC_SCon: Encoder: Channel select for Speed Control	Selection of encoder channel for speed configuration. Feedback signal for speed controller
P 0522		ENC_PCon: Encoder: Channel select for Position Control	Selection of encoder channel for position information. Feedback signal for position controller
<b>Parameter settings apply to P 0520, P 0521, P 0522</b>			
(0)	OFF		No encoder selected
(1)	CH1		Channel 1: SinCos on X7
(2)	CH2		Channel 2: Resolver on X6
(3)	CH3		Channel 3: Option on X8

Table 1.9 Encoder configuration

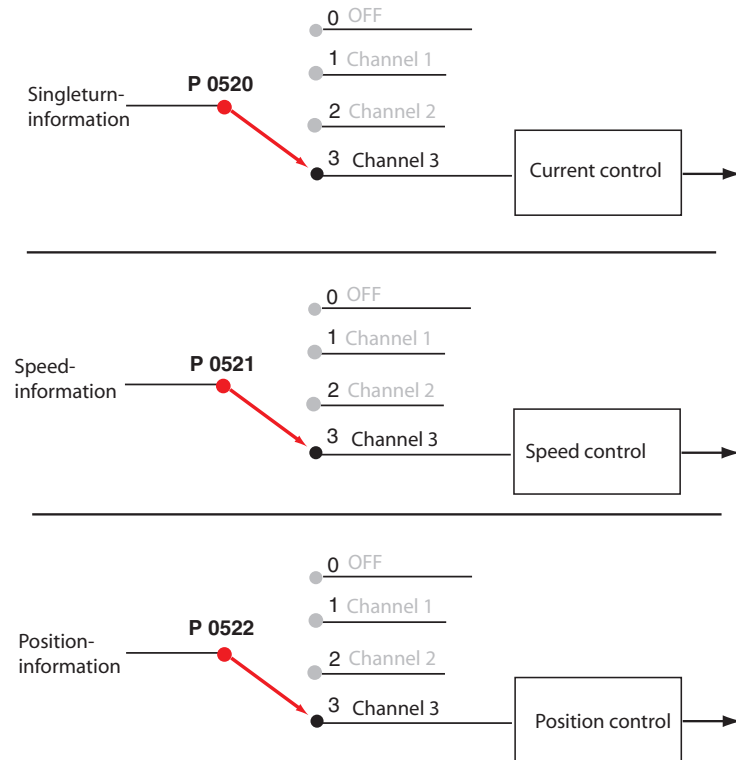

Figure 1.4 Display of encoder configuration for encoder channel X8



**ATTENTION:** A parameter can only be written or read with the appropriate access rights (e.g. "Local administrator"). A changed parameter must always be saved on the device.

When editable online, a parameter executes a reaction on the device immediately, so inputs must always be carefully checked.

## Specification Option 2 - Technology

*TTL encoder simulation / TTL master encoder*

ID No: 1306.21B.1-00

Date: 02/2011



**LTI DRIVES GmbH**

Gewerbestraße 5-9  
35633 Lahnau  
Germany  
Fon +49 (0) 6441/ 96 6-0  
FAX +49 (0) 6441/ 96 6-137

Heinrich-Hertz-Straße 18  
59423 Unna  
Germany  
Fon +49 (0) 2303/ 77 9-0  
FAX +49 (0) 2303/ 77 9-397

www.lt-i.com  
info@lt-i.com

### **We reserve the right to make technical changes.**

The content of our Operation Manual was compiled with the greatest care and attention, and based on the latest information available to us.

We should nevertheless point out that this document cannot always be updated in line with ongoing technical developments in our products.

Information and specifications may be subject to change at any time. Please visit <http://drives.lt-i.com> for details of the latest versions.